

Installation Manual

Gen 1 SERIES

 **Aqua-Hot**[®]
An AIRXCEL Brand

Gen 1 DIESEL
1000516



Contents

Caution Notes.....	1
Installation Checklist	2
Declaration of Conformity.....	3
Introduction	4
System Features	7
Installing the Aqua-Hot	8
Exhaust & Air Intake Systems	9-11
Aqua-Hot Layout.....	13
Fuel Supply	14
Fuel System Priming	17
Domestic Water System.....	18
Connections and Sensors.....	20
Connecting to 12V DC Power & AC Power	21
Aqua-Hot LCD	22
Operating the LCD.....	23
System Schematic	29
Winterizing, Service, Maintenance	30
System Checks.....	30
First Operation.....	31
Troubleshooting.....	32
Warranty	33

WARNING

WHAT TO DO IF YOU SMELL GAS

- Evacuate all persons from the vehicle.
- Shut off the gas supply at the gas container or source.
- Do not touch any electrical switch or use any phone or radio in the vehicle.
- Do not start the vehicle's engine or electric generator.
- Contact the nearest gas supplier or qualified service technician for repairs.
- If you cannot reach a gas supplier or qualified service technician, contact the nearest fire department.
- Do NOT run the first operation until it has been confirmed there are no gas leaks.
- Do not turn on the gas supply until the gas leak(s) have been repaired.



Caution Notes

As you read this information, take particular note of the NOTICE, CAUTION, WARNING, and DANGER symbols when they appear. This information is important for safe and efficient use of the Aqua-Hot system.

NOTICE signals a situation where potential damage to the Aqua-Hot could occur.

NOTICE

CAUTION signals a situation where potential harm or risk of minor or moderate injury could occur if you do not follow instructions.

CAUTION

WARNING signals a hazardous situation where potential harm, risk of serious injury, or death could result if instructions are not followed.

WARNING

DANGER signals a situation where immediate risk of serious injury or death will result if instructions are not followed.

DANGER

NOTE: This manual will also use notes sections similar to this one to draw attention to features and practices which must be observed.

DANGER



Water temperature over 52°C can cause severe burns instantly, or death from scalds. Children, disabled, and elderly are at highest risk of being scalded. See instruction manual before setting temperature at water heater. Feel water before bathing or showering! Temperature limiting valves are available.

Installation Checklist

Introduction:

The following table is a checklist of important items that need to be completed for a successful install of the Aqua-Hot heater in your RV. Please confirm each item is properly completed before utilizing the Aqua-Hot heating system.

Should additional assistance be needed, please contact the Technical Support team at +39 0424 1953311, Monday through Friday, between 8:00 to 16:00 CET. You can also email at info@airxcel.eu. Authorized Service Centers can also be found online at <https://airxcel.eu>.

WARNING!

Read and understand all instructions **before** installing the Aqua-Hot unit. Aqua-Hot Heating Systems is not liable for damage resulting from failing to follow instructions contained in this, and any other Aqua-Hot documentation relevant to this unit.

Improper installation, adjustments, service and maintenance can cause personal injury or loss of life. Reference the installation and user manuals **before** installation or service.

Contact your authorized service center or Aqua-Hot Heating Systems if you have any questions **before** starting installation.

All vehicle installations must comply with national legislation and regulations.



This unit is CE certified. Any modifications made to this unit not outlined in official literature or expressly authorized by Aqua-Hot will void this certification.



WARNING

If the information in this manual is not followed exactly, a fire or explosion may result, causing property damage, personal injury, or death.

Completed	Description	Page No.
	Aqua-Hot Installed	8
	Air Intake System & Exhaust System Installed	9-11
	Fuel stand pipe installed in vehicle fuel tank	14
	Fuel lines properly installed	14-17
	Fuel system components connected to fuel line in order	14-17
	Fuel line hose clamps fully tightened	14-17
	Domestic Water System plumbed to the Aqua-Hot	18
	Domestic Water Pressure through the Aqua-Hot regulated to 2.8bar	18
	RV Thermostats OR Thermistors wired to Aqua-Hot	20
	12VDC connected to Aqua-Hot	21
	220VAC connected to Aqua-Hot	21
	Aqua-Hot LCD mounted in correct orientation	22
	System checks performed before first operation	30
	First operation properly performed	31



CE DECLARATION OF CONFORMITY

Applicant:
Aqua-Hot Heating Systems, LLC
7501 Miller Drive, Frederick, CO 80504

Representative:
Can srl
Via G. Apollonio 11
36061 Bassano del Grappa Italy

We declare that the product(s) described below:

Product Name: Parking Heater/Water Storage Heater
Product Model: AHE-GXE-DX1 (Diesel) and AHE-GXE-PX1 (Propane)

Complies with the provisions of the following European Directives:

1. Low Voltage Directive 2014/35/EU
2. Drinking Water Directive (EU) 2020/2184 ~ 98/83/EEC
3. Heating Systems in Vehicles UNECE Regulation No. 122
4. Radio Interference suppression in motor vehicles UN ECE R10
5. End-of-Life Vehicle Directive 2000/3/EC

The product(s) have been assessed by the application of the following standards:

- 2014/30/EU** Electromagnetic interference
- EN 55014-1:2021 EMC Emissions
 - EN 55014-2:2021 Electromagnetic compatibility. Requirements for household appliances
- EN 60335-1 2021 60335-1;2012+A15:2021** Household and similar electrical appliances. Safety General requirements.
- EC 60335-1:2020** CMV Safety of electrical appliances for household and similar purposes
- IEC 60529:1989 Ingress of water
 - IEC 60990:2016 Leakage of current Fig 4
- IEC 60335-2-21 Ed. 7.0 b:2022 (+ Amendments)** Electrical Appliances Part 2-21: Particular Requirements for Storage Water Heaters
- DIN 2001-2, KTW**
- EN16421 Drinking water supply from small units and non-stationary
 - EU 2020/2184-98/83/EEC and DIN2001-2



GM
Gary Miller
Date: 23 May 2023
Director of Engineering and Manufacturing

Airxcel Brand Portfolio



Introduction

Read and understand all instructions **before** installing the Aqua-Hot system. Aqua-Hot Heating Systems is not liable for damage resulting from failing to follow instructions contained in this, and any other Aqua-Hot documentation relevant to this unit.

- Read this manual **before** installing or using the Aqua-Hot System to reduce the risk of injury to persons or damage to the equipment.
- The product identity label contains specifications of the unit, to what standards it has been tested, and important safety notices.
- Disconnect electric wiring to the Aqua-Hot System before welding or plasma cutting the RV to avoid damage to the electrical components.
- The GEN-1 tank must have a cold water inlet pressure regulator set to 2.8bar or below to avoid damage to the tank.



- Use caution when working on or near any diesel fuel system.
- DO NOT connect the 12-volt DC power to the Aqua-Hot if the vehicle requires welding.
- Use special caution when children are present. Children must not be allowed to play with the heater or perform cleaning and maintenance.
- All vehicle installations must comply with the requirements of National Legislation and Regulations standards.
- At maximum operating temperature, the hot air outlet will be very hot that may result in serious burns or injury. Be aware of hot surfaces.
- The burner produces very hot temperatures that can ignite surrounding flammable materials. The burner should be turned off when loading or unloading flammable materials.



System Overview

The Aqua-Hot Gen-1 Heater is a forced air heating system that can provide heat and supplementary hot water using a built-in electric heating element and a diesel burner.

There are three options for heating:

- **Diesel Mode:** the heater automatically adjusts power according to temperatures.
- **Electric Mode:** manually select either the 900W or 1800W heating mode according to the power supply capacity of the shore power.
- **Hybrid Mode:** when the power demand is low, the electric heating is prioritized. For higher heating needs, the burner will automatically activate.

Important Notes:

- A qualified installer or service technician must perform equipment installation or service.
- Installation, repairs, and warranty work may only be carried out by a qualified technician. The heating system must be installed in accordance with local codes, or the National Legislation and Regulations.
- Aqua-Hot will not be liable for problems or damage caused by the system being installed by untrained technicians.
- This heating system has been certified for installation only in recreational vehicles as a Class I Appliance, not certified for use in boats.
- The Aqua-Hot heating system operates independently of the vehicle engine and is connected directly to the electrical system of the vehicle or towable.
- Please read this manual and follow instructions to avoid injuries during installation and/or operation.

NOTE: Contact your Authorized Service Center or Aqua-Hot Heating Systems if you have any questions **before** starting installation. Information can be found online at <https://airxcel.eu>.

All vehicle installations must comply with national legislation and regulations.

 This unit is CE certified. Any modifications made to this unit not outlined in official literature or expressly authorized by Aqua-Hot will void this certification.

Safe Installation of the System

Become familiar with the installation process before installing in the vehicle or towable.

- Make sure to protect the unit during installation. Do not drop or stand on the heater.
- Routing of the fuel system and electric (220VAC & 12VDC) must be isolated and not in contact with fuel supply at any point of the installation.
- Only turn off the burner at the switch in the interior of the vehicle. It must be obvious to the user when the heater is switched on or off.
- Do not disconnect the 12V DC power supply prior to the purge cycle.
- Only shut down the burner via the battery disconnect in the case of an emergency or danger.
- Do not allow the wiring or wiring harness to come into contact with sharp edges on metal panels. The wires can become damaged and short circuit and potentially cause a fire. Use caution when installing the wiring.
- Protect any vehicle parts near the burner from excessive heat damage, or from contamination from fuel.
- Make sure the internal combustion burner will not pose a fire hazard even in an overheat situation. Take care in placing the heater with enough space from vehicle parts and that the burner will have ample ventilation.
- The serial label must be visible and legible after the heater has been installed.
- All precautions must be taken to minimize the risk of personal injury or damage to the burner or vehicle.

Fuel Supply

- Do not use the heater in enclosed spaces such as a garage. The fumes produced from the exhaust can be toxic. Do not use the burner while refueling or while other appliances are being serviced or refueled.
- The fuel system must comply with the technical and administrative regulations of the respective country of use.

Exhaust System

- Do not operate the heater in an enclosed space or a space that does not have exhaust ventilation. Fumes from the exhaust may be toxic.
- The exhaust system must be positioned so that the fumes will not get into the interior of the vehicle through ventilation openings or windows.
- *Exhaust termination location must comply with National Legislation and Regulations standards.*



WARNING

If the information in this manual is not followed exactly, a fire or explosion may result, causing property damage, personal injury or death.

Air Intake Inlet

- The burner combustion chamber air must not be taken from the interior of the vehicle, only fresh air from the exterior.
- An intake line is required for the intake air.
- The air inlet must be positioned in an unobstructed manner.

WHAT TO DO IF YOU SMELL GAS

- Evacuate all persons from the vehicle.
- Shut off the gas supply at the gas container or source.
- Do not touch any electrical switch or use any phone or radio in the vehicle.
- Do not start the vehicle's engine or electric generator.
- Contact the nearest gas supplier or qualified service technician for repairs.
- If you cannot reach a gas supplier or qualified service technician, contact the nearest fire department.
- Do NOT run the first operation until it has been confirmed there are no gas leaks.
- Do not turn on the gas supply until the gas leak(s) have been repaired.
- Installation and service must be performed by a qualified installer, service agency, or gas supplier.

THE AQUA-HOT'S EXHAUST IS HOT!

- Do NOT operate the burner inside an enclosed building.
- The heater must be switched OFF when refueling.
- The heater is not to be operated while the vehicle is being refueled, if the towing vehicle is being refueled, or if the vehicle is in an enclosed space.
- The heater is not to be used while any appliances are being refueled or serviced.
- Aqua-Hot will not be liable for problems and/or damage caused by the system installed by untrained technicians.



WARNING

The heating system can produce dangerous CO gas when the fuel system is operating if not properly installed or operated. Read all safety instructions before install or use.



Aqua-Hot®
An AIRXCEL Brand

For full details and installation requirements, please see installation and owner's manuals.

Minimum Service Clearances:
 Front: 10 cm
 Back: 2.5 cm
 Sides: 1.25 cm
 Top: 5 cm
 Bottom: No clearance Necessary

This appliance must be installed in accordance with local codes, or in absence of local codes, follow EN-1949.



Max Tank Pressure	4,5 bar (450 kPa)
Tank Capacity	10L
Power (DC)	12VDC, 10A, 120W Max
Power (AC)	240VAC, 7.8A, 1800W Max
Burner	Diesel, 4kW

Model: 1000516
Serial Number: XXXXXXXX

NOTE: This product label is attached to the side of the Aqua-Hot, and provides a ready reference to specifications, test standards, and important safety notices.



Figure 1

Main Technical Specifications		
Rated Voltage	DC12V	
Operating Voltage Range	DC10.5V - 16V	
Short-Term Max Power	8 - 10A	
Average Power Consumption	1.8 - 4A	
Fuel Type	DIESEL	
Fuel Heat Power (W)	2000	4000
Fuel Consumption (ml/H)	286/322	609/656
Quiescent Current	1mA	
Warm Air Delivery Volume (m3/h)	287 (max)	
Water Tank Capacity	10L	
Maximum Pressure of Water Pump	2.8bar	
Maximum Pressure of System	4.5bar	
Rated Electric Supply Voltage	220V	
Electrical Heating Power	900W	1800W
Electrical Power Dissipation	3.9A	7.8A
Working Environment	-25 °C - +80 °C	
Working Altitude	≤5000m	
Weight (kg)	15.6kg (dry)	
Dimensions (mm)	510 x 450 x 300	
Protection Level	IP21	

Aqua-Hot Gen 1 Heater	
1.	Heater
2.	Combustion Air Inlet
3.	Exhaust Outlet
4.	Controller Cover
5.	Plastic Frame Feet
6.	Aluminum Frame Feet
7.	Circulated Air Intake
8.	Cold Water Connection (Inlet)
9.	Diesel Fuel Connection
10.	Hot Water Connection (Outlet)
11.	Fan for Combustion Air
12.	Water Tank
13.	Warm Air Outlets (Upper)
14.	Warm Air Outlets (Lower)
15.	Recessed Grips
16.	Electronic Control Unit
17.	LCD Control Screen

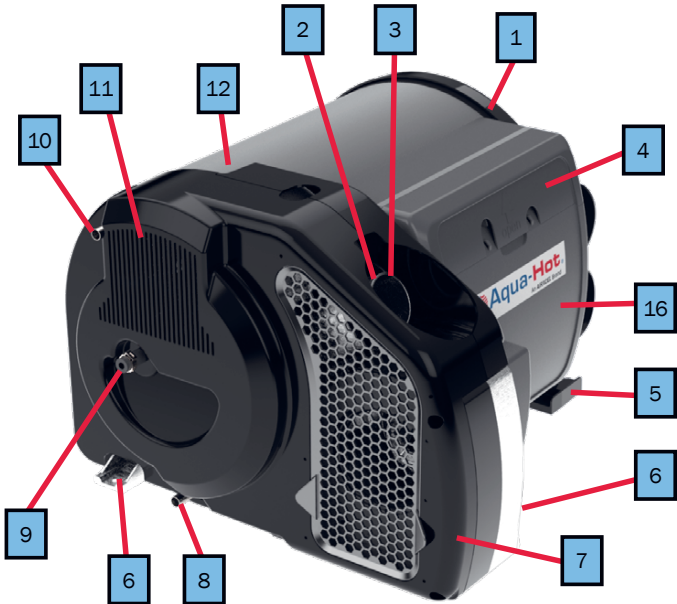

Figure 2



Figure 3



Figure 4

Installing the Heater

Install the Aqua-Hot in a compartment which protects the unit and allows service access to the top and front panel of the Aqua-Hot. This heater must be installed in the RV's interior.

1. Reference the following illustrations below for mounting information.
2. Secure the Aqua-Hot to the RV floor using appropriate mounting hardware to suit flooring material and tolerances.
3. The Aqua-Hot is best placed where easy access to the top and front is guaranteed for service.

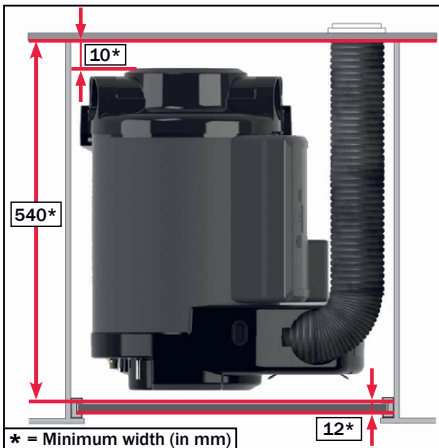

Figure 5

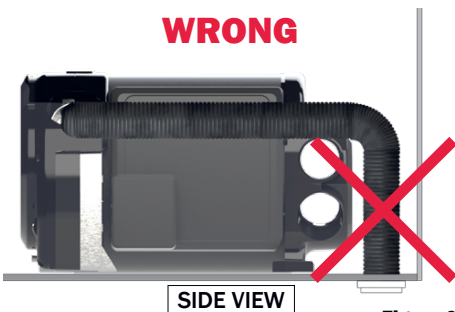

Figure 6

Support and Clearances

Make the following considerations when supporting the Aqua-Hot to ensure its most optimal operation and location. Dimensions for the mounting tabs are shown below. NO COVER IS ALLOWED ON THE HEATER

- Ensure that the floor of the mounting location can support at least **32kg**.
- Use (3) mounting screws to the aluminum/plastic frame feet to secure the Aqua-Hot in place on the RV floor to prevent damage to the fuel lines during driving and operation.
- The best place for the Aqua-Hot heating system is in the center cabinet or storage space to ensure that the heater evenly distributes heat, making sure there is ample space to remove the service panels on the top and side.
- Exhaust pipe minimum length is 60cm and the maximum length is 200cm.

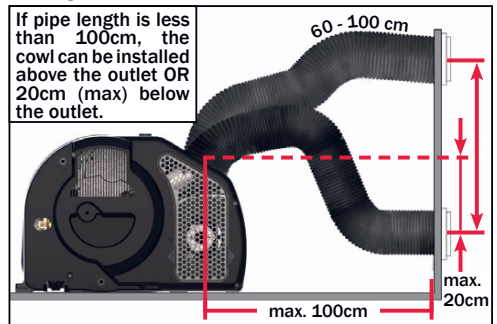

Figure 7

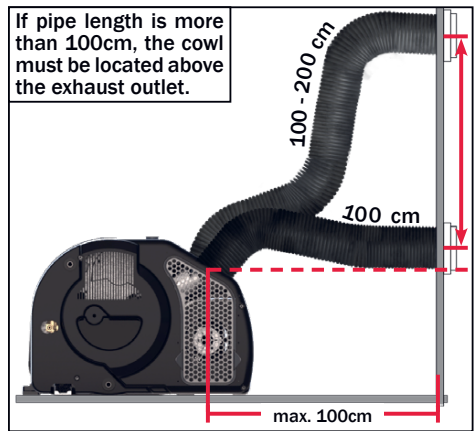

Figure 8

Exhaust & Air Intake System

The exhaust pipe passes through the air intake pipe. The exhaust pipe should be slightly shorter than the intake pipe. The exhaust vent must be installed on the side wall.

The length of the intake and exhaust pipe is 1 meter. Reference figures 5-8 for permissible routing.

- The air intake shall not be supplied from living areas. The air intake opening must not point in the direction of travel. It should be free from potential clogs from snow, debris, or water.
- There is no air pressure difference between the exhaust gas outlet or air inlet.
- The air intake pipe must be positioned in a way that the intake will not terminate within the vehicle interior.
- The wall vent must be positioned away from a ventilation window (min. 30cm) and refueling port (min. 50cm) to avoid fumes from re-entering the RV.

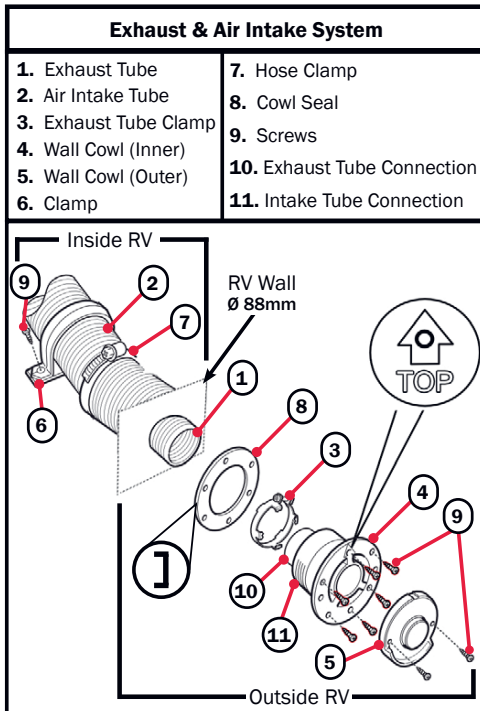

Figure 9

Exhaust Cowl (Air inlet & outlet) Installation

- Cut the exhaust pipe and air intake pipe to length.
- If either end is damaged or bent, cut off approximately 2cm.
- Slide the air intake pipe over the exhaust pipe.
- Select a flat mounting surface so that intake air can enter from all sides.
- Drill one hole (Ø 88mm) in the RV wall and seal with the gasket (Figure 9 #8) smooth side facing the exhaust vent and gasket facing the RV wall (Figure 9 #3).
- Slide a hose clamp (#3) over the exhaust and insert the pipe into the drilled hole. Tighten the clamp (torque 3.4 - 4Nm).
- Insert the air intake pipe onto the ridges of the exhaust cowl (#11).
- Use 6 screws (#9) to secure the exhaust cowl. Make sure "TOP" faces upward.
- Use 2 screws to secure the exhaust cowl cover and then secure the exhaust pipe to the RV wall with the mounting clamp (#6).



Refer to BS ISO 8178 "Internal Combustion Engines" and ISO 11042 "Exhaust Gas Emissions" for relevant information.

- Should this particular application require modification, please contact Aqua-Hot Heating Systems at +39 0424 1953311 for further assistance.

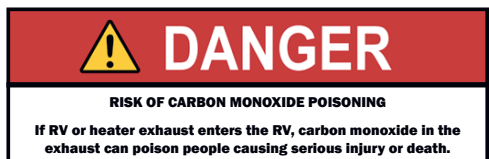

Connecting Air Inlet to Heater

There should be 20mm at the end of the exhaust - pipe should be compressed, not straightened.

- Insert the exhaust pipe (#2) on the exhaust port as deep as possible.
- Attach the clamp (#1) on top and tighten.
- Place the air intake pipe (#4) over the inlet port.
- Place the clamp (#3) and tighten.

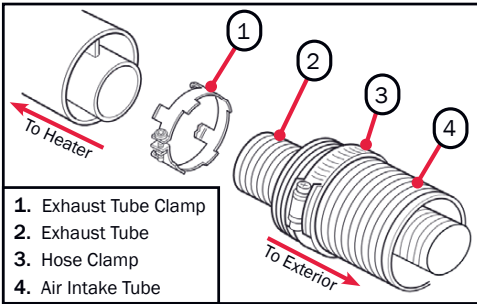

Figure 9a

Circulated Air Intake Installation

- The heater draws in circulated air from inside of the RV
- The air intake opening must be installed in a position so no exhaust fumes can be drawn in.
- The air inlet grate (#1) between the RV's living space and GEN-1's compartment space must be at least 150 cm².

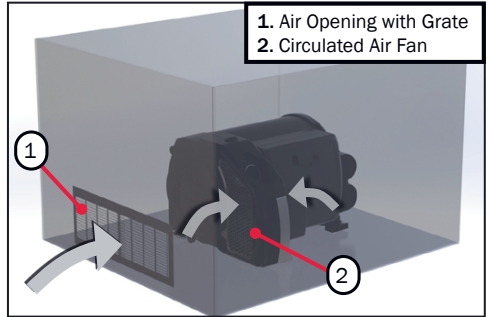

Figure 9c

When using a internal muffler style exhaust:

- Insert exhaust pipe with o-ring (#2) into the exhaust port as deep as possible.
- Attach c-clip (#1) into the two holes on the heater's exhaust port to secure the exhaust in place.
- Place the air intake pipe (#4) over the inlet port.
- Place the clamp (#3) and tighten.

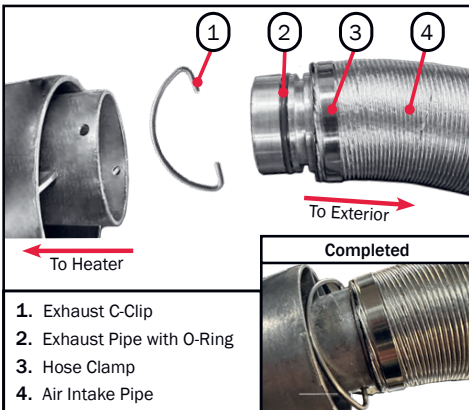

Figure 9b

Warm Air Intake & Distribution Installation

- Warm air is distributed to the RV interior by flexible air ducts.
- The air ducts must be properly installed for the heater to correctly operate. The ducting from each outlet should be at least 1 meter long. Equal length ducts are ideal for even air distribution throughout the cabin.
- The longer ducts should be connected to the upper outlets.
- At least **3 of the 4** warm air outlets must be used for proper distribution of heat.
- The air outlets are connected to air ducts with an outside diameter of 65mm. They must meet local requirements for pressure piping quality requirements..
- Each air duct must have at least one end outlet. The air outlet duct must be firmly inserted into the connection port.
- It is recommended to use 90° elbows for bends, keep the bends to a minimum
- If the duct length is less than 2m, the air duct should not be installed higher than the air duct connection on the GEN1.
- If the duct length is less than 50cm, form a U-shaped trap near the air outlet (Figure 11) to prevent unwanted interior heating when the system is only in hot water mode

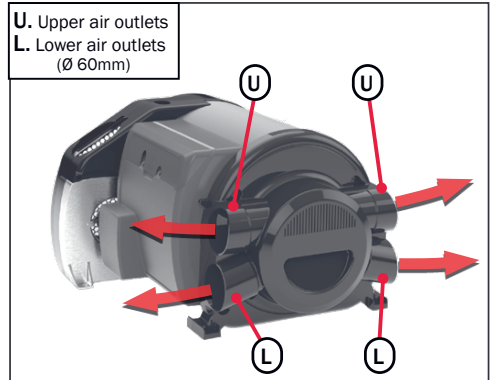

Figure 10

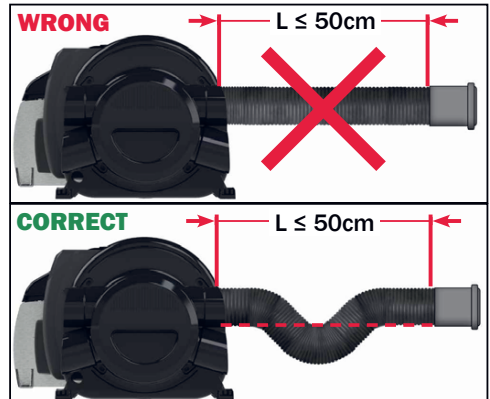

Figure 11

Installation for Air Outlet Vents:

1. Drill a hole with a diameter of 6cm into the wall.
2. Insert the outlet into the drill hole from the FRONT side of the wall. Attach outlet to wall with screws.

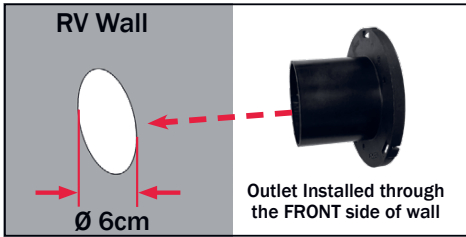

Figure 12

3. Attach air vent to outlet.



Figure 13

4. Insert the warm air duct onto the outlet (from the back side of the wall) until it fits tightly. Clamp air duct to outlet securely.

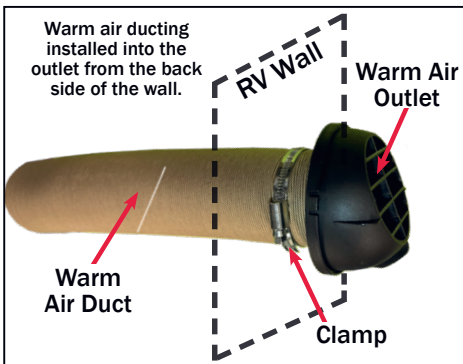

Figure 14

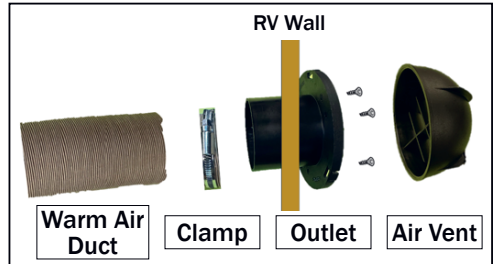
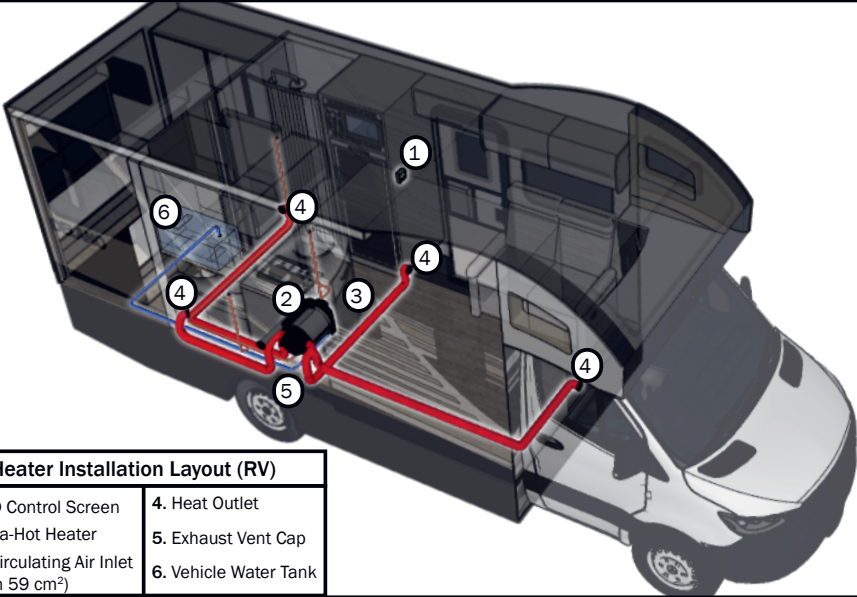

Figure 15

NOTE: The illustration below is just a sample for the layout of the Aqua-Hot heating system. Actual placement may vary on the individual design of the RV. For questions or assistance, contact us at +39 0424 1953311.



Heater Installation Layout (RV)

- | | |
|---|-----------------------|
| 1. LCD Control Screen | 4. Heat Outlet |
| 2. Aqua-Hot Heater | 5. Exhaust Vent Cap |
| 3. Recirculating Air Inlet
(min 59 cm ²) | 6. Vehicle Water Tank |

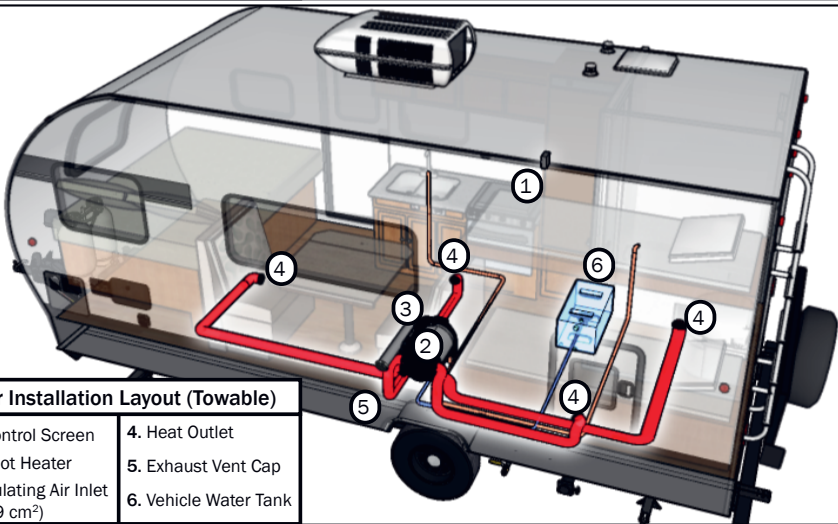

Heater Installation Layout (Towable)

- | | |
|---|-----------------------|
| 1. LCD Control Screen | 4. Heat Outlet |
| 2. Aqua-Hot Heater | 5. Exhaust Vent Cap |
| 3. Recirculating Air Inlet
(min 59 cm ²) | 6. Vehicle Water Tank |

Figure 16

Fuel Supply

Fuel System Requirements

- The diesel fuel supply should be drawn directly from the vehicle's main fuel tank if applicable. A separate 10L fuel tank may be installed if necessary.
- The fuel tank should be equipped with a dedicated fuel pick-up pipe. Make sure the fuel standpipe does not impair the operation of the vehicle's fuel delivery or fuel gauge in any operating mode.
- The fuel standpipe must be positioned vertically and the end should sit at least 25mm above the tank bottom.
- The hole on the fuel tank should be a diameter of 25mm. Make sure edges are smooth to confirm good sealing.

Fuel Standpipe Installation

1. Drill a 25mm hole through the top of the fuel tank.
2. Remove sharp pieces and smooth edges with sandpaper or an emery cloth.
3. Determine the length of the standpipe so the end is at least 25mm above the bottom of the fuel tank.
4. Cut off excess standpipe at a 45° angle, remove any sharp edges.
5. Loosely assemble parts.
6. Place an O-ring between the inner wall of the tank and the intake nozzle with a washer and provided nut. Tighten the nut to a torque of 6Nm (± 1 Nm). Do NOT over-tighten the nut to prevent the rubber washing becoming distorted.

WARNING

Failure to follow instructions on the fuel delivery system can cause damage to the Aqua-Hot, the burner, or the RV. It may cause serious personal injury. Please follow instructions carefully.

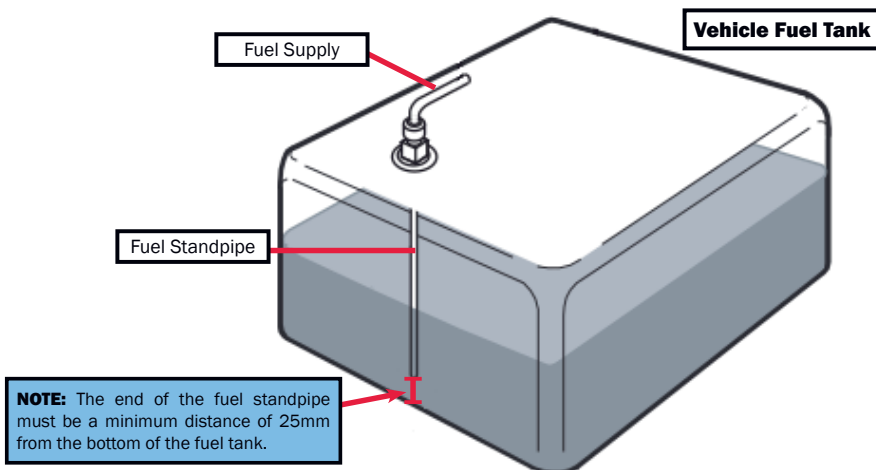

Figure 17

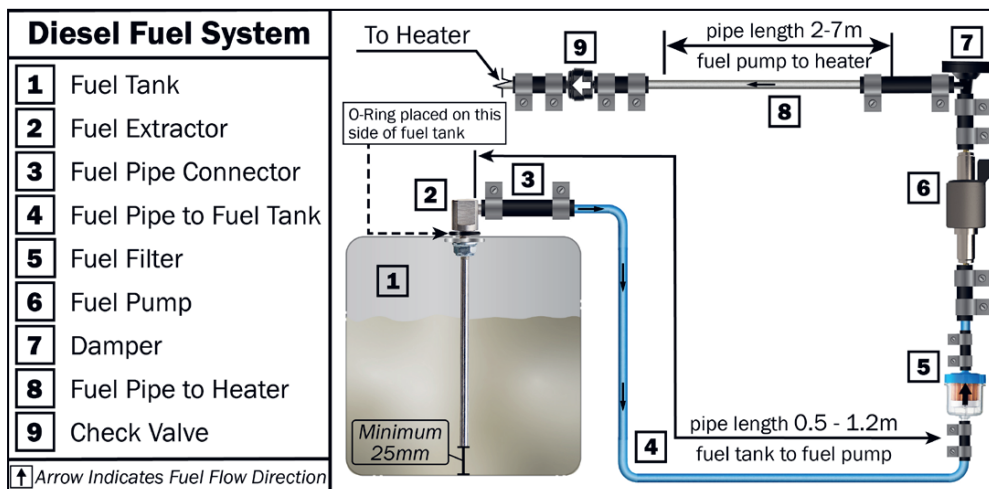

Figure 18

Fuel Lines Requirements

- Please refer to the example diagram shown above.
- Use the provided fuel line with the included couplers and clamps.
- The fuel line should not be descending from the fuel pump to the burner - see Figure 18.
- The fuel line should be properly secured to avoid sagging.
- The fuel line must be installed in a manner that won't cause damage to the fuel line (i.e. close to exhaust).
- The fuel line should be mounted and secured with hose clamps. The hose clamp must be tightened so that the two tabs on the clamp touch each other.
- The fuel line must be kept as short as possible. The total length of the fuel line should not exceed 8.2m. The maximum length of the inlet fuel line is 1.2m, and the maximum length of the pressure is 7m.
- The fuel line should be laid out as flatly as possible, avoiding extreme rises in height to eliminate any air traps.
- The fuel system must comply with National Legislation and Regulations.

WARNING

Do NOT use bio-diesel with the fuel lines. Doing so will result in damage to the burner and fuel system. Please follow instructions to ensure safe operation. Always check for any fuel leaks before operating the burner.

Fuel Filter

- A fuel filter should be installed before the fuel pump to ensure that clean fuel is delivered to the burner at all times.
- Make sure the fuel filter is installed in an accessible area, so it can be replaced during service.
- It is recommended to replace the filter, tubing connection head and clip every year.
- The filter can be mounted vertically or horizontally; note the installation position and direction of flow (see Figure 22).

Fuel Pump

- Fuel Pump is required to be installed horizontally. It is not recommended to mount the assembly rotated 180° (see Figure 20).
- It must be fixed with a rubber clamp and should be inclined upward. Do not install near the exhaust pipe.

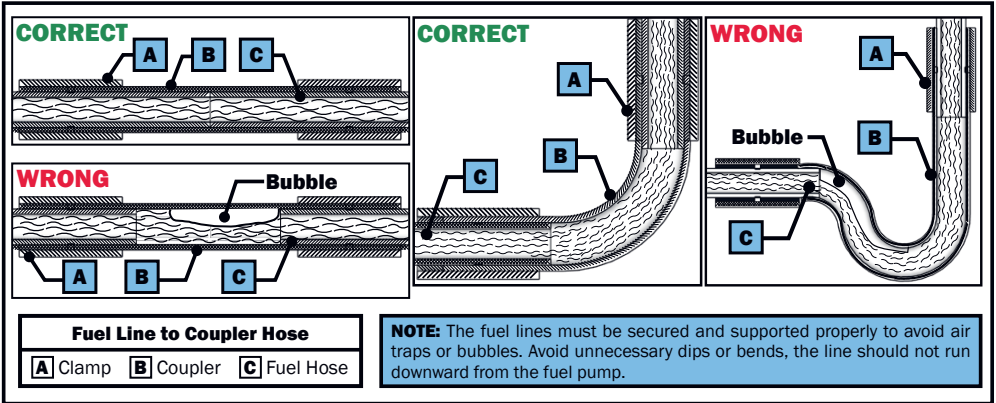

Figure 19

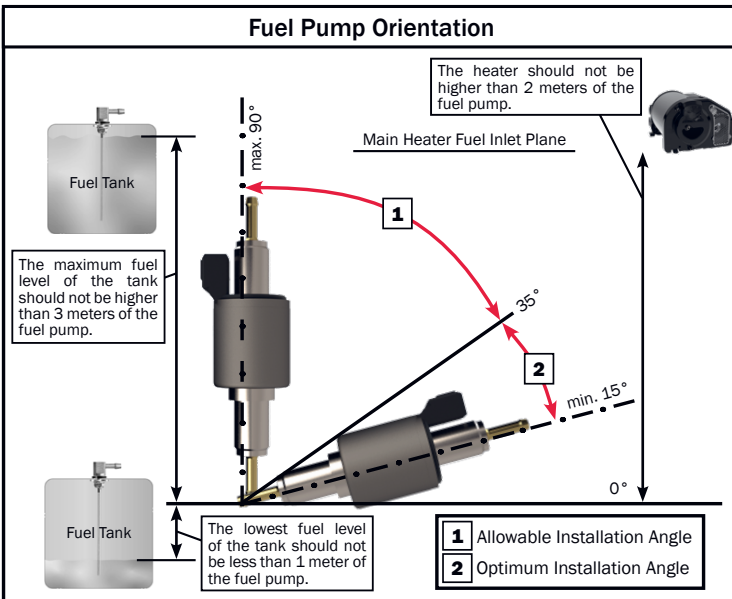

Figure 20

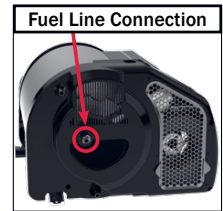

Figure 21

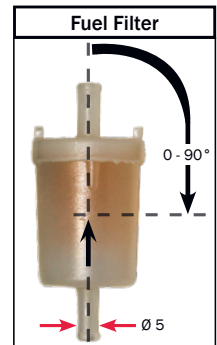

Figure 22

Fuel System Priming

For proper operation, the fuel system must be primed and free of air bubbles.

- Priming must be done prior to first operation or after the fuel filter has been replaced
- The fuel line must only be primed with the fuel line disconnected from the system.
- Place the disconnected end of the fuel line into a bucket or other receptacle to catch any fuel.
- With the fuel line and check valve disconnected from the system, navigate to the GoOil feature in the settings menu.
- Allow the GoOil feature to run until no air bubbles are seen in the clear fuel line.
- Reconnect the fuel line and check valve to the heater.



WARNING

DO NOT use the GoOil feature when the fuel line is connected to the heater.

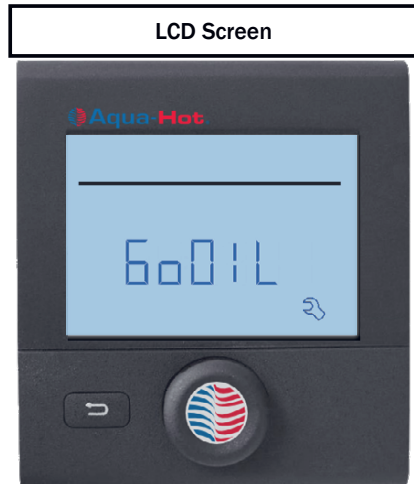

Figure 23

Domestic Water System

- All water pipes, valves, and connectors must be safe for drinking water, pressure resistant (up to 4.5 bar), and hot water resistant (up to 80 °C).

NOTE: The water supply to the heater should not exceed 2.8bar in pressure. If water pressure is above 2.8bar, a pressure regulator is required.

- If the water pump is to be submerged, it is required to install a non-return valve between the pump and first water faucet on the cold water line.
- A pressure relief valve (4.5bar) must be installed to protect the system from overpressure.
- The non-return valve (#6 Figure 24) must be installed in the proper direction:

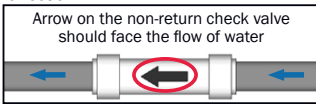

- All connections must be secured by clamps or crimp rings.

The domestic water system must be installed by a qualified technician and must follow all local code requirements or regulations.

DANGER

Water temperature over 52 °C can cause severe burns instantly, or death from scalds. Water temperature coming from the heater will be at 71 °C. Feel water before bathing or showering! Temperature limiting valves are available.

Reference the diagram below for more information.

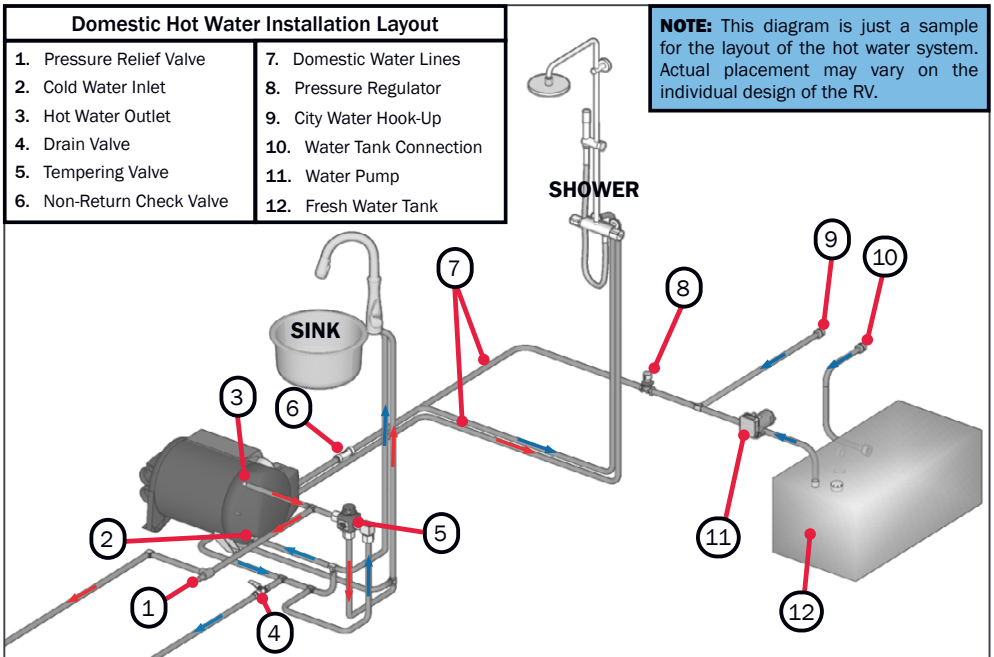

Figure 24

Filling the Water System

Before filling up the system with domestic water, confirm that the relief valve and drain valve are closed.

- Turn on the pump power supply at the pump switch.
- Open a hot water faucet in the RV and keep open until all air is purged from the line and water continuously flows.
- Keep the water on until all air is purged and the water tank is filled.

Disinfecting the Domestic Water System

NOTICE

The Aqua-Hot Heating components are not compatible to prolonged exposure to sodium hypochlorite (bleach or liquid bleach). Using products containing bleach, including water refreshers, may cause corrosion of the domestic water lines, resulting in a catastrophic failure of the Aqua-Hot system by creating leaks that cannot be repaired. This damage is not covered by the Aqua-Hot warranty.

If disinfecting the hot water system, be sure to follow any current national regulations or any other applicable local standards for Water Systems.

NOTE: Extended exposure to household bleach will corrode the components of the Aqua-Hot will potentially dramatically shorten the operational lifetime of the Aqua-Hot. Under no circumstances is the Aqua-Hot to be exposed to household bleach for extended periods of time.

DANGER

Risk of Severe Burn or Death from Scalds. Water temperature over 51°C (123.8°F) can cause severe burns instantly or death from scalds. See instruction manual before setting temperature at water heater. Feel water before bathing or showering. Temperature limiting valves are available, see manual.

WARNING:
 HOT WATER CAN PRODUCE 3RD DEGREE BURNS
 - IN 6s at 60°C (140°F)
 - IN 30s AT 54°C (129.2°F)
 WATER DELIVERY TEMPERATURE MIXING VALVE WAS FACTORY SET AT 49°C (120.2°F).
 CONTACT QUALIFIED SERVICE PERSONNEL FOR ADJUSTMENTS.

LDE-003-260

Connecting the Thermistor

The thermistor must be installed or the system will not operate properly. It is recommended to install the sensor away from direct heat.

Installation

1. For best performance, the sensor should be mounted unobstructed to the ambient cabin air.
2. Drill two mount holes and a third hole for the wires. Attach the thermistor using two fasteners.
3. Attach the necessary length of 0.5mm² wire to each end of the included wire in order to reach the GEN1 unit. Terminate each wire with the included spade connectors to connect to the GEN1 unit.

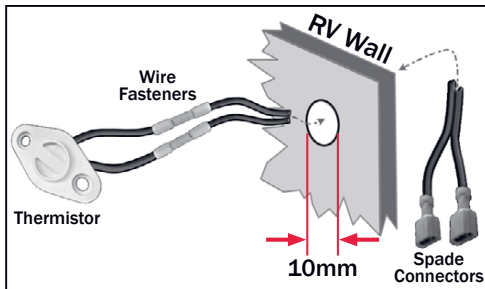

Figure 25

Electrical Connections

The controller is located on the heater under the cover as shown below. The cover can be removed by pressing and sliding the arrow to release. Make sure the connecting cable is not pulled out when removing the cover.

Install wires away from sharp edges and metal surfaces, exhaust pipes, and fuel lines.

Connector cables and plugs should not be forced. Use tie-cables and fasten them to the housing with straps. The cables should not be able to loosen or disconnect when vehicle and heater are in operation.

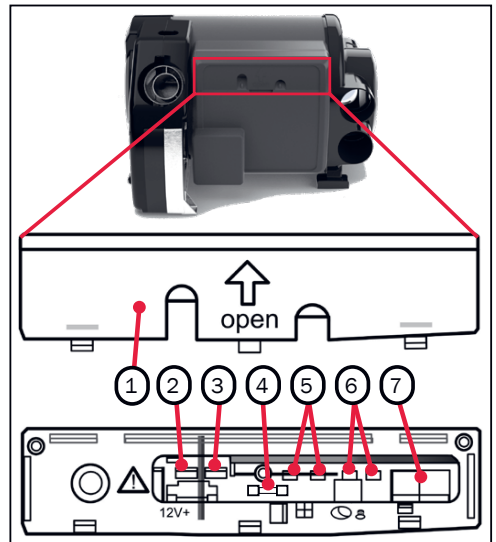

Figure 26

Controller Connections	
1. Connection Cover	4. 20A Fuse (2m)
2. +12VDC Input Voltage	5. Window Switch
3. -12VDC Ground	6. Thermistor
	7. LCD Controller

Connecting to 12V DC Power



DO NOT connect 12V DC power to the Aqua-Hot if the vehicle requires welding. Electrical welding will cause serious, irreversible damage to the Aqua-Hot.

The section will outline the requirements, steps, and information necessary to connect the Aqua-Hot to the vehicle's 12V DC power system.

Follow all guidelines and pay attention to all notes. Failure to adhere to these guidelines can inhibit unit performance, and may cause damage to the Aqua-Hot and/or the RV.

- Installation must be performed by a qualified professional according to current national regulations.
- The 12-volt supply to the heater must be connected to the battery and protected by an in-line fuse (20A).
- The main power and ground wires for the system should be installed directly to the vehicle battery as shown in the diagram below. The lines must be protected.
- The power supply cable must have a diameter of:
 - 2 x 2.1mm² up to 5m in length
 - 2 x 3.3mm² up to 6m in length

For lengths greater than 6m, please contact Aqua-Hot.



ELECTRICAL SHOCK HAZARD

The boiler must be connected to protective earth.

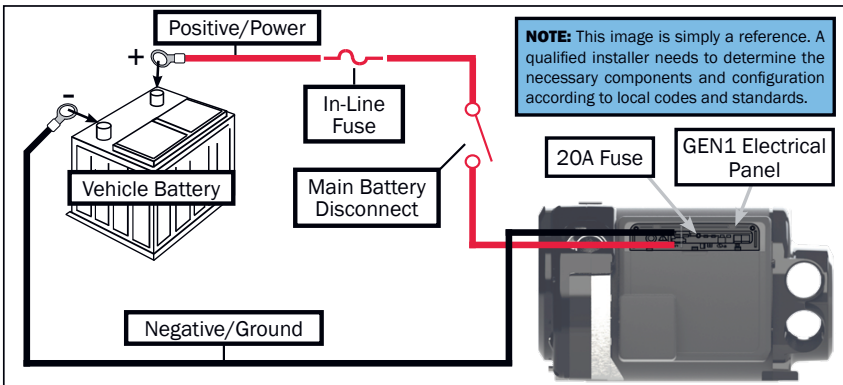

Figure 27

Connecting the Aqua-Hot to AC Power

This section will detail how to connect the Aqua-Hot to the vehicle's AC electric system. When the RV is connected to an AC power source (plugged into shore power/generator), the Aqua-Hot boiler tank is heated by a 900W/1800W electric element. When ELECTRIC is turned on, DC power at the controller permits flow to the AC relay, which then activates the relay to send AC power to the electric element. The element will then heat the tank to between 74-82 °C.

- Installation must be performed by a qualified professional according to current national regulations.
- The boiler must be connected to a 220V AC supply permanently and be protected with a 10A breaker. The 220V AC must be separate from 12V DC.
- It must be possible to disconnect the power to the boiler, either an easily accessible plug or a circuit breaker.

AC Wires		
Connection	Type	Color
AC1	Neutral	Black
AC2	Ground	Yellow/Green
AC3	Line	Red

Connecting 12V DC power for LCD Display

The following section will detail the requirements to connect the Aqua-Hot LCD Display to 12V power.

- The LCD Display should be connected to 12V power without being routed through the main battery disconnect.
- A positive and ground wire located on the back of the LCD Display are to be connected to 12V power through a 1A fuse.
- A 1A fuse is required and should be placed in the vehicle's fuse box or in-line at an accessible location.

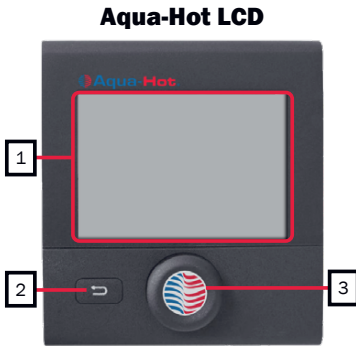

Figure 28

- 1** Display Area **2** Return Button **3** Rotary Button

Mounting Considerations:

- Install the LCD controller in an interior waterproof location and at eye level.
- The screen requires at least 30mm of backside clearance to allow room for cables and connections.
- Reference the diagrams to the right for more information.

Mounting Procedure:

1. Cut a 84mm x 74mm hole in the RV wall.
2. Route the corners of this cutout with a 3mm diameter bit.
3. Using four M3x10 screws, secure the LCD bracket into place over the cutout just made.
4. Connect the LCD cable to the back of the LCD screen.
5. Secure the LCD screen into the mounting bracket using the (1) M3x6 screw.

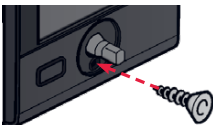

6. Install the turn knob onto the face of the screen.

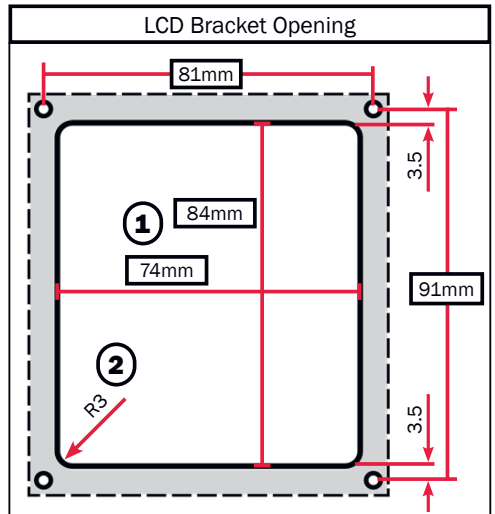
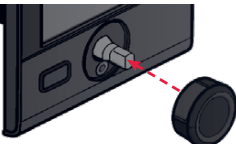

Figure 29

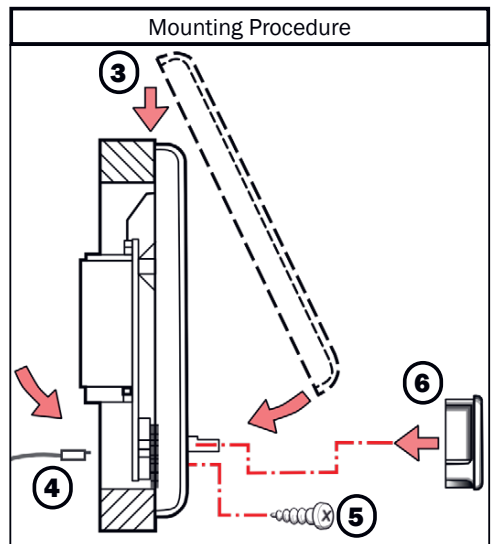
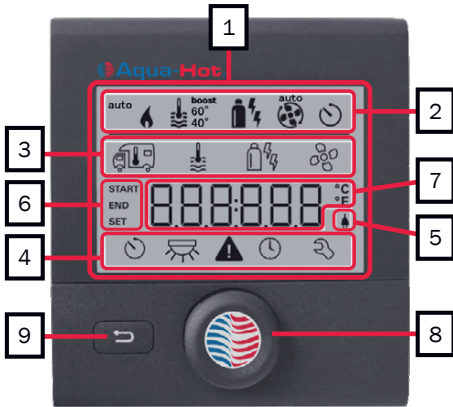

Figure 30

Operating the LCD



1 Display Area	6 Timing Display
2 Status Display	7 Parameter Setup Display
3 Menu Bar (top)	8 Rotary Button/Knob
4 Menu Bar (bottom)	9 Return Button
5 220V Electrical Display	

Display and Control Section:

- The information is displayed on the screen with a back-light
- In the menu bar (#3, 4), the function of the LCD can be selected. The operating parameters are shown on the status bar (2) and display bar (5, 6).
- After the 220V is supplied to the system, the 220V power supply indication column (5) displays the power supply sign
- During heater operation, set the parameter bar (7) to display start/end times, and room temperature.
- Press the return button (9) to return to previous interface.

Rotary button (8)

- Select, modify, and save icons for menu bars 3 & 4 by rotating the knob.
- Tap the button to confirm saving and return to main menu.
- Press and hold the button (+3seconds) to turn on/off LCD.

Power ON:

Hold the rotary button for 3seconds to turn on LCD. After a few seconds, the time is displayed as 00:00.

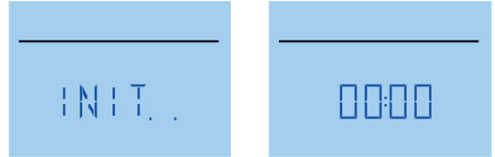

Click the rotary button to display the initial options in the display.

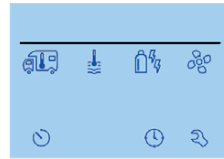

Clock setting (current time setting)

- Click the rotary button to display the icon in the menu bar (3).

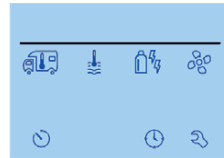

- Use the rotary button to select "Set Clock" icon in the menu bar (4).
- Click the rotary button to enter the clock settings.



- Use the rotary button to set the time. "A-" is displayed in the morning and "P-" is displayed in the afternoon
- Click the rotary button again to determine the time, then the minute display flashes.
- Set the minute with the rotary button.
- Click the rotary button to confirm the value and exit the clock setting.
- Rotate button to start
- Press the rotary button for 3 seconds, the LCD will start.

Operating the LCD

Shutdown

Press the rotary button for more than 3s at the initial interface to shut down. When the LCD switch is turned off, the heating process and any connected equipment are also automatically turned off. The parameters before shutdown are retained.



Downtime Process (Cool-Down Cycle)

Since the heater has a higher residual heat after heating and a post-cleaning need, the fan typically runs for a few minutes for cooling.

Heating Function Settings

The heating function setting should first set the fuel, and then select water heating or room heating or simultaneous heating, and finally set the fan speed. The default heating function settings is the fuel setting and the fan speed setting ECO.

Energy Setting

- Rotate the button to select the fuel icon in the menu bar (3).
- Click on the selected icon.

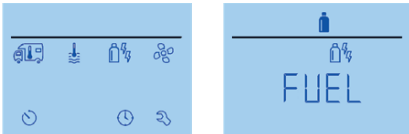

- Use the rotary button to select the desired fuel mode.
- Click the rotary button to confirm.

If the fuel type is not selected, once the heater starts to operate (room temperature, hot water icon is activated), the status bar shows the type of fuel selected during the previous heating process or the fuel type set at the factory.

Working Mode	Energy Mode
FUEL	Diesel
MIX 1	Electric 900W + FUEL
MIX 2	Electric 1800W + FUEL
EL 1	Electric 900W
EL 2	Electric 1800W

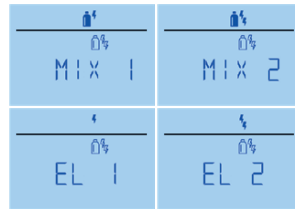

Adjustment of Interior Temperature

- Click the rotary button to display the icon in the menu bar (3). Select the room temperature heating system with the rotary button according to the connected device.
- Confirm the selection by clicking the rotary button on the selected room temperature icon.
- Use the rotary button to select the desired temperature.
- Click the rotary button to confirm its value.

Temperature Display	°C / °F
Temperature Range	5-30°C / 41-86°F
Increments	1° C/F

This flame icon will be on when room temperature heating starts, this icon will flash until the predetermined room temperature is reached.



Adjustment of Water Heating

- Click the rotary button to display the icon in the menu bar.
- Use the rotary button to select the desired water temperature setting level.
- Click the rotary button to confirm

Working Mode	Energy Mode
OFF	Water heating is off - icon will not show
ECO	Water Temperature target of 40°C
HOT	Water Temperature target of 60°C
BOOST	Heats the water for 40 minutes or until the water temperature reaches 60°C



. This icon will flash until the predetermined water temperature is reached.

In the "heating and hot water mode", the water temperature of 40°C can only be stored for a limited time (room heating priority).

Adjustment of Fan Speed (when air heating is enabled)

- Click the rotary button to display the icon in the menu bar.
- Use the rotary button to select the desired fan speed setting level.
- Click the rotary button to confirm.

Working Mode	Energy Mode
OFF	Fan is off - icon will not show
VENT	Circulation ventilation. Can choose 10 levels of fan speed.
ECO	Low fan speed
LOW	Mid-speed
HIGH	High fan speed
BOOST	Fastest fan speed



Adjustment of Vent Fan Speed

NOTE: Vent Fan is for air circulation without heating.

- Only available when air heating is not enabled
- Select OFF or VENT

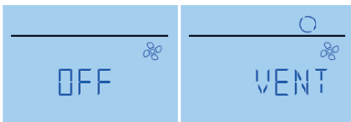

- If VENT is selected, set the fan speed between 1-10.

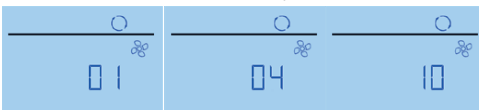

Heating Start

After the setting is finished, press the return key or wait for 10s to enter the clock interface, and the heating starts. The clock and set temperature are displayed alternately.

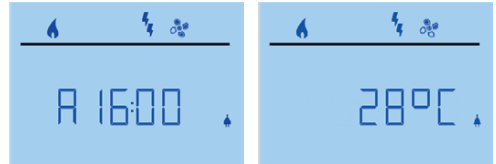

Heating End

Press and hold the rotary button for 3 seconds to shut down.

Timing Heating Settings

- Click the rotary button to display the icon in the menu bar (3).
- Click the rotary button to enter the timing settings.

 **WARNING**

DANGER OF TOXIC EXHAUST FUMES

Even if the vehicle is stopped, unmanned, the activated time switch will turn on the heater. Exhaust gases from heaters may be toxic in confined spaces such as garages, workshops, and repair shops.

If the vehicle is parked in a closed room:

- Turn off the fuel supply to the heater.
- Turn off the timer switch of the LCD switch.
- Turn off the heater on the LCD switch. Press and hold the rotary button for 3 seconds to turn off.

Enter the Start-up Time

- Use the rotary button to set the start time.
- Click the rotary button to confirm and proceed to the next setting.

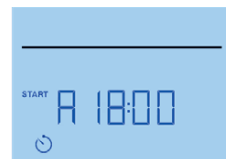

Operating the LCD

Enter the End Time

- Use the rotary button to set the end time.
- Click the rotary button to confirm and proceed to the next setting.

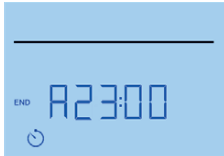

Set Room Temperature

- Use the rotary button to set the desired temperature
- Click the rotary button to confirm and proceed to the next setting.

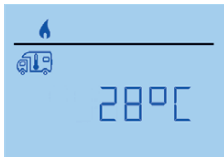

Set Water Temperature

- Use the rotary button to set the desired temperature
- Click the rotary button to confirm and proceed to the next setting.

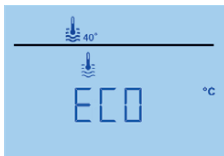

Fuel Mode Selection

- Use the rotary button to set the desired fuel mode
- Click the rotary button to confirm and proceed to the next setting.

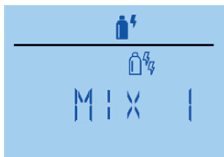

Select Fan Speed Level

- Use the rotary button to set the desired fan speed
- Click the rotary button to confirm and proceed to the next setting.



Enable Timer

- Use the rotary button to select Enable Timing (ON). If OFF is selected, the timer is canceled, but the settings are saved.
- Click the rotary button to confirm and proceed to the next setting.

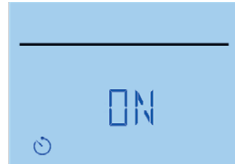

The time switch is only enabled once until it is disabled (turned off) or powered down. If the timer switch is programmed and enabled, the time switch icon is displayed in the status line (2). The timing icon flashes if the time switch is enabled and activated.

Cancel Timer

- With the timing set, use the rotary button to select the timing setting. Click the rotary button to enter the settings.
- Use the rotary button to select the cancel timing (OFF). If you select ON, continue to use timing. Click the rotary button to confirm that the cancellation timing is valid. But the previous settings are still saved

Parameter Settings

The content after the parameter setting is maintained after the power is turned off. Use the rotary button to select the "Settings" icon in the menu bar (4). Click the button to enter the settings.

Voltage Inquiry

- Click the rotation button to display the voltage: 12.0V.

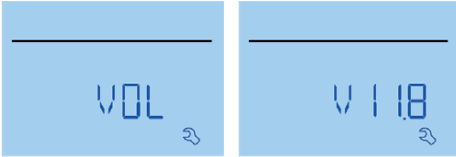

Air Pressure and Temperature Inquiry

- Click the rotation button to select the at ATMOS icon.
- Click the rotary button to enter the selection



- Use the rotary button to switch between atmospheric pressure and ambient temperature.

Atmospheric pressure: 99kPa **Ambient temperature:** 26°C

Offset Setting

The external temperature sensor of the heater can be adjusted separately depending on the installation of the sensor. The offset setting can be in the range of -5°C to 5°C. The deviation is 1°C.

- Click the rotation button to select the OFFSET icon.
- Click the rotary button to enter the selection

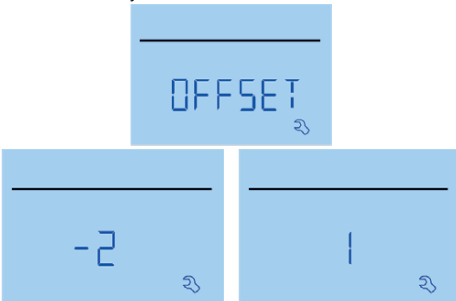

Switching Temperature Units

Use the knob to switch between Celsius and Fahrenheit, then click to confirm

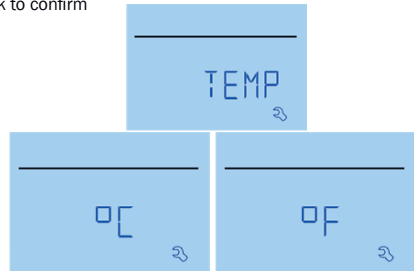

LCD Backlight Adjustment

The LCD backlight has 10 levels of incremental adjustment.

Use the rotary button to select the BRIGHT icon and click the rotate button to enter the settings.

The brightness of the LCD changes as the rotary button rotates. After confirming by clicking the rotary button, return to the previous operation. The backlight brightness is set to 6 by default.

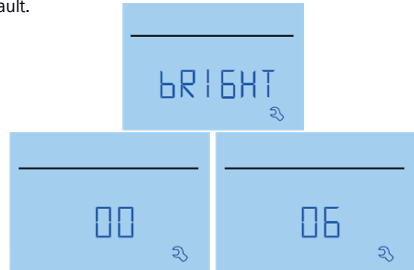

Time Settings

Use the rotary button to select the time format setting icon and click the rotary button to enter the settings. Use the rotary button to select the 12h or 24h icon and click the rotary button to confirm. The default setting is 24h.

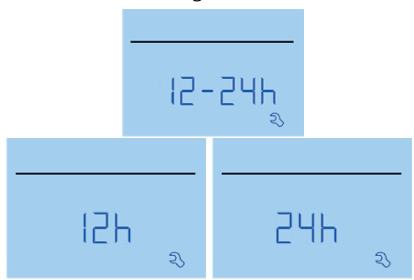

Operating the LCD

Fast Pump Settings

NOTE: The Fast Pump/GoOil feature must only be used for system priming with the fuel line disconnected from the heater. Do not attempt to use this feature with the fuel line connected to the heater.

Select pump oil icon GoOil with rotary button.

- Click on the rotary button to enter the fast pump oil. The default fast pump time is 90 seconds. The remaining time can be adjusted with a knob.
- Press the return key or stop the fast pump if the pump oil time exceeds the set value.

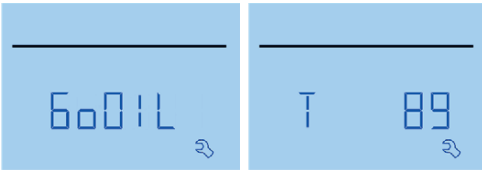

Software Version Number

- Use the rotary button to select the INDEX icon and click the rotary button to enter the query item.
- Use the rotary button to view the information of the LCD switch or the information of the main controller.
- Click the rotary button or want to go back to return to the previous operation.

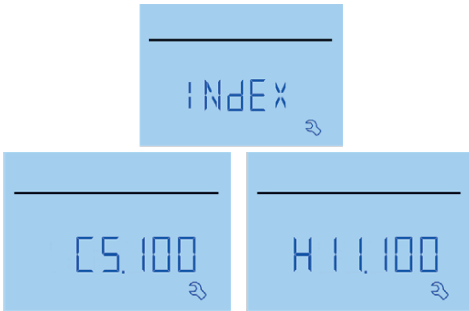

C5.100 - LCD Version **H11.10** - Master Controller Version

Factory Settings

- The reset function resets the LCD switch to factory settings. All previous settings will be deleted. All devices used before RESET is installed and powered.
- Use the rotary button to select the RESET icon and click the rotary button to display the factory setting PR SET.
- After confirming, the initialization "INIT....." is displayed.

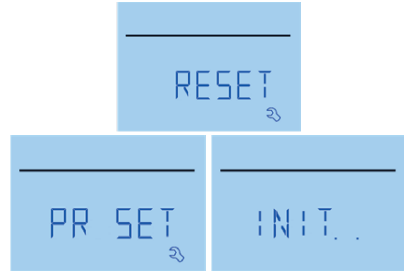

Fault Display

- Use the rotary button to select the icon and click the rotary button to display the current warning code (for troubleshooting, please refer to the relevant heater instruction manual).
- There are faults in the fault that are automatically recovered and manually recovered after repair.
- An automatic recovery fault is a warning fault in which an operating parameter has exceeded a defined normal working range and reached an undefined state. In this case, the device will continue to run and the warning symbol (▲) will be displayed in the menu bar (4) without warning code. After the fault is repaired, the warning symbol disappears automatically (it can also be manually restored), and the device continues to work according to the original settings. For example: warning fault code W 120 H.
- A manually recovered fault means that the fault code is displayed in the parameter setting 8 field (7) when the fault occurs. The cause of the fault can be determined and remedied by the help of the troubleshooting guide. The fault code disappears after a few seconds, and the warning disappears, and the warning symbol is displayed in the menu bar (4).
- Select Reheat after the fault is identified and resolved, first remove the fault code. Press the rotary button to display the fault code, then press the rotary button, the displayed fault code disappears and return to the initial time interface. Re-enter the heating parameters to initiate heating. If the fault is removed, the heating will be normal or the fault will occur again. The LCD switch will jump to the "Fault" menu again, the warning symbol will be displayed again, and the affected device will still be in the warning state. Since the fault has not been eliminated, if you want to return to the set level, press the back button (9). For example: fault code E 31 H. Shutdown and power off can also eliminate faults.

The fault code table and troubleshooting methods can be found in the tenth fault code table at the end of the manual.

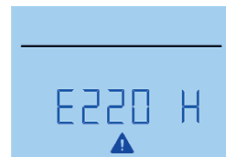

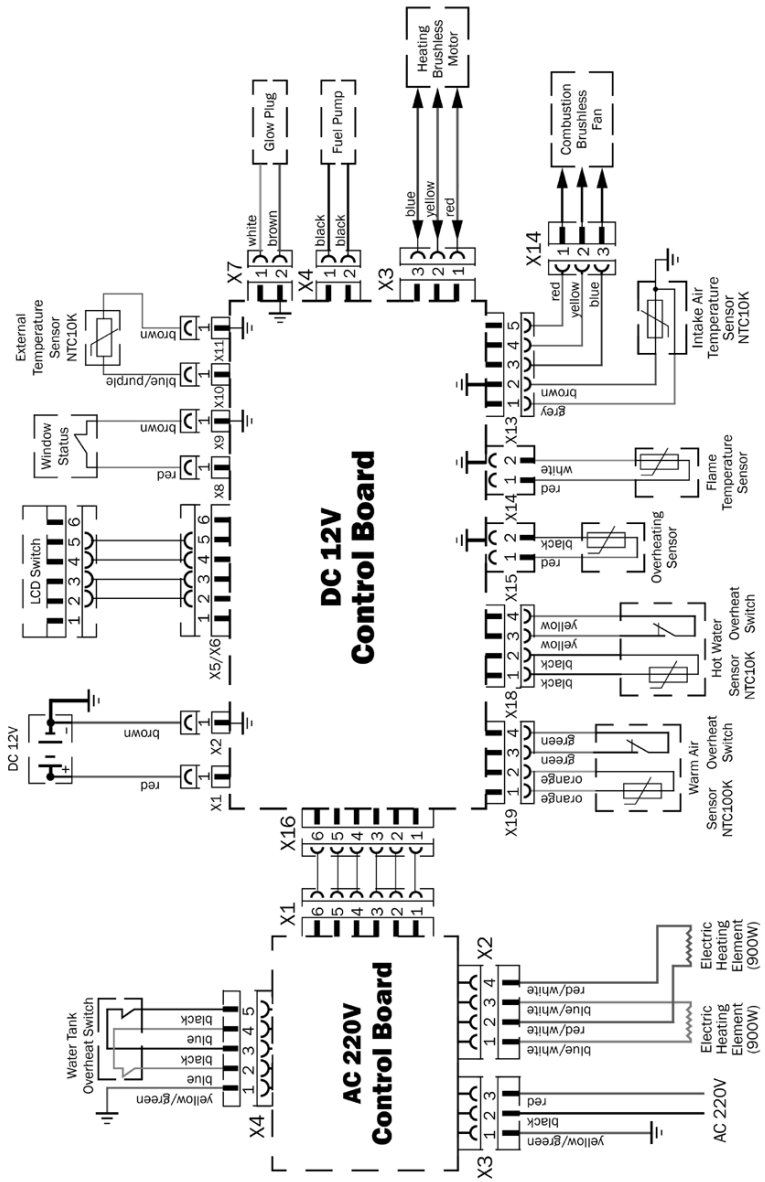

Winterization

To avoid freeze damage to the system, the heater must be drained through the drain valve completely. If water is left in the system in below freezing temperatures, it can cause severe damage to the system that is not covered under warranty.

NOTE: The Aqua-Hot can continue to be used for interior heat once the domestic hot water system has been winterized.

- Turn off power supply and open hot water faucets in the RV.
- Place a container under the drain valve to catch the fluid.
- Open the drain valve and allow the fluid to drain out completely.

It is recommended to winterize if the RV will be stored for a long time or the system will not be used, and it is below freezing.



WARNING

Not winterizing the Aqua-Hot when freezing temperatures are present will result in serious damage to the Aqua-Hot domestic water heating system. The warranty does not cover freeze damage.

Maintenance & Storage

It is recommended to have the following service done once a year:

- Replace the fuel filter
- Check the air ducting, air intake and exhaust outlet for blockages or damage
- Check for damage or breaks in the fuel lines and wiring.

If the system has not been used for long periods of time, thoroughly flush all hot/cold water lines before use. It is recommended to run the heater at least once a month for 10-20 minutes to ensure optimum heater condition.

The water tanks must be cleaned regularly, minimum of twice a year. When the RV is driving or in storage, the temperature range should not exceed the range of 40-85 °C to prevent damage to the electronic components.

System Checks

Please do the following checks prior to the first operation to confirm the installation was done properly and safely.

1. Test all water connections and fuel connections/lines for any leaks. Make sure all the hose clamps are properly positioned and secured.
2. Ensure there is protection on any sharp edges or objects for the water and fuel lines, and wiring.
3. Make sure there is more than a ¼ tank of fuel and the operating voltage to greater than 11.5V.
4. Make sure the power and ground connections are properly secured and installed.
5. Check that the fuses are in their proper, specified locations.
6. Make sure the fuse boxes are secure and protected from any water sources.
7. Ensure the vehicle battery is mounted properly and all connections are secure, and has a full charge.
8. The exhaust tube should be a safe distance from any flammable materials (at least 50mm).
9. Exhaust opening should be a safe distance away from any vehicle interior openings and should be directed to not cause back pressure while driving.
10. The combustion air intake should get fresh air away from the direction of travel.
11. Ensure the air intake system is properly secured.
12. All plumbing and fuel lines should be purged of any air, as any air can cause a lock-out.

Once the system checks are complete and it has been confirmed that all is properly and safely installed, please continue to the first operation.



WARNING

AQUA-HOT HEATING UNIT

Avoid the Risk of Explosion:

- Switch Heater off at filling stations and areas where explosive materials, fumes, and dust may collect.

Avoid the Risk of Asphyxiation:

- Never operate heater in closed spaces such as garages and shops without adequate ventilation or exhaust extraction.

For further information on the safe operation of your Aqua-Hot heater, refer to your Aqua-Hot operating manual.

LDE-101-128

Aqua-Hot First Operation

The first operation of the Aqua-Hot heater may not light up perfectly. This is normal and may take a couple tries to get the fuel lines purged of air before a successful start-up. It is normal for a bit of smoke to produce from the exhaust.

NOTE: Make sure to perform all the system checks on Page 30 prior to starting this initial start up of the heater.



NOTE: It is recommended to run the system for at least 20 minutes every month to ensure optimum heater condition.

NOTE: The heater is thermostatically controlled. The element and/or burner will automatically maintain the temperature of the RV interior and domestic water.

Activation Instructions:

1. Make sure power supply to the Aqua-Hot is on. Use the LCD to operate.
2. Confirm that the water tank is adequately filled. Make sure to flush the domestic water system thoroughly with clean water prior to use.
3. Confirm the water system and heating loop has been properly purged of any air.
4. Confirm there is adequate diesel fuel and the fuel system has been purged.
5. Hold the rotary button/turn knob down for 3s to wake up the LCD. Make sure LCD system is set up.
6. Select FUEL, EL, or MIX to turn on energy type. The heater should begin to heat.
7. Allow approximately 20 minutes for the system to heat the interior. Turn on a hot water faucet, and allow to run until hot water flows. Once there is hot water, close the faucet. This will verify that the system is operating as it should.

Once these checks have been confirmed, the heater is now ready for normal operation and use.

 <p>LDE-200-810</p>	 <h2 style="margin: 0;">WARNING</h2>
	<p>Burn Hazard</p> <p>Heater may have hot surfaces that can cause severe burns.</p> <p>DO NOT touch or service until equipment has cooled.</p>

Troubleshooting

- Ensure that the system is supplied with electrical power and there are no blown fuses.
- Ensure that there is at least ¼ tank of fuel in the vehicle fuel supply and the fuel filter is not clogged.
- Make sure all the electrical and plumbing connections are connected and secure.
- Ensure there are no faults on the LCD. If there are, determine the fault and remedy. Refer to the table below for the fault code.

Fault Codes		
Error Code	Fault Name	Remedy
10	Over-voltage	Check vehicle power supply
11	Low Voltage	Check vehicle power supply
21	Warm air outlet temperature sensor disconnect	Check temperature sensor connections
22	Warm air outlet temperature sensor short circuit	Check temperature sensor wiring
23	Water temperature sensor disconnect	Check temperature sensor connections
24	Water Temperature sensor short circuit	Check temperature sensor wiring
25	External temperature sensor disconnect	Check temperature sensor connections
26	External Temperature sensor short circuit	Check temperature sensor wiring
27	Combustion support temperature sensor disconnect	Check temperature sensor connections
28	Combustion support temperature sensor disconnect	Check temperature sensor wiring
31	Combustion Failure	<ul style="list-style-type: none"> • Check gas supply system • Check combustion inlet and outlet are blocked • Check ignition coil, electrode • Flame sensor
32	Combustion failure	<ul style="list-style-type: none"> • Check gas supply system • Check combustion inlet and outlet are blocked • Check Flame sensor
33	Flame sensor fault	<ul style="list-style-type: none"> • Check flame sensor lead wire • Check flame sensor
41	Warm air outlet overheats	Check air outlet for blockages
42	Warm air overheat switch protection	<ul style="list-style-type: none"> • Check whether air outlet is blocked • Check warm air overheat switch

Error Code	Fault Name	Remedy
43	Water overheat	<ul style="list-style-type: none"> • Check water tank levels • Check sensor wiring/connections • Check air outlet for blockages
44	Warm air overheat switch protection	<ul style="list-style-type: none"> • Check air outlet for blockages • Check warm air overheat switch
45	Overheat fault	<ul style="list-style-type: none"> • Check air outlet for blockages • Check water temperature sensor • Check warm air sensor
51	Communication fault	Check interconnecting cable
61	Fuel Pump Break	<ul style="list-style-type: none"> • Check fuel pump lead for damage • Check fuel pump wire connections • Replace fuel pump • Replace controller
62	Fuel pump short circuit	<ul style="list-style-type: none"> • Check fuel pump lead for damage • Check fuel pump wire connections • Replace fuel pump • Replace controller
63	Electric element circuit broken	<ul style="list-style-type: none"> • Check power supply voltage • Check resistance at room temp (0.2/12V) • Clean any carbon build-up • Replace controller
65	No power to electric element	Replace controller
81	Combustion fan disconnect	Check combustion air blower
82	Combustion blower boot failure	<ul style="list-style-type: none"> • Check blower motor lead wire • Check combustion air blower
83	Combustion blower speed too low	Check combustion air blower motor
84	Warm air blower motor disconnect	Check warm air blower motor
85	Warm air blower motor boot failure	<ul style="list-style-type: none"> • Check blower motor lead wire • Check warm air blower motor
86	Warm air blower speed too low	Check warm air blower motor
110	Window alarm	Check window switch cable
120	Low Voltage Fault	Check power supply and connections
220	220V Disconnect	Check AC 220V/110V power supply

Heater Lock-out Reset Procedure

To reset the heater from a lock-out, simply turn off the heater and disconnect power supply to the heater, wait for 20 seconds, then reconnect power supply and restart the system.



2-YEAR LIMITED WARRANTY AQUA-HOT® HYDRONIC HEATING SYSTEM

Aqua-Hot Heating Systems Inc. warrants the Aqua-Hot Heater to be free from defects in material and workmanship under normal use and service for a period of two years on both parts and labor commencing upon the original date of registration of the vehicle. Replacement parts are warranted for the remainder of the Heater's standard warranty coverage or for six months, whichever is greater. The intent of this warranty is to protect the heater's end-user from such defects, which would occur in the manufacturing of the product. Thus, problems due to improper specifications, improper installations, improper use, the use of accessory parts or parts not authorized by Aqua-Hot Heating Systems Inc., repair by unauthorized persons, and damage or abuse of the heater are specially excluded from warranty coverage.

For additional information, or to obtain a warranty repair authorization, please contact the Aqua-Hot Heating Systems Warranty Administrator at +39 0424 1953311 from 08:00 to 16:00 CET Monday through Friday or visit <https://airxcel.eu>.

My Comfort Zones are On-Board

Vehicle:

Purchased From:

Dealer Information:

Name:

Location:

Phone Number:

Heating System:

Serial Number:



Scan the QR code on the right with your mobile device to take you to the website to register your Aqua-Hot product.

Installation Manual

Gen 1 SERIES



Gen 1 DIESEL
AHE-GXN-DX1



AIRXCEL EUROPE - CAN S.R.L.
Via G. Apollonio 11
36061 Bassano Del Grappa - (VI)
Italy

Visit us online at <https://airxcel.eu>
Tel +39 0424 1953311
Fax +39 0424 1953399

©2023 Aqua-Hot Heating Systems, LLC.