

Use and Care Guide

Gen 1 SERIES

 **Aqua-Hot**[®]
An AIRXCEL Brand

Gen 1 DIESEL
1000516



Thank you for equipping your RV, coach, or caravan with an Aqua-Hot hydronic heating system! We deeply value your business and we are grateful for the trust you have placed with Aqua-Hot Heating Systems, LLC. Our customers are our top priority and we are committed to providing best-in-class products, service, and support.

We understand how important comfort is to you as a recreational vehicle or manufactured home owner; therefore, we have designed a heating system to significantly improve all of your comfort levels. Additionally, the Aqua-Hot hydronic heating system is a low-emissions, fuel efficient system that adds thousands of dollars in value to your RV or home.

We know that you must be eager to get underway, but take time to read and understand this Use and Care Guide to understand the basic functionality of the Aqua-Hot. This guide should be maintained in legible condition and kept in a safe, accessible location for future reference.

Should you have any suggestions on how we can better serve you, please do not hesitate to contact us.

Technical Support can be contacted at +39 0424 1953311. Hours of operation are 08:00 to 16:00 (CET) Monday through Friday.

The Aqua-Hot heating system is protected by the finest warranty in the industry (read about it at the back of this manual).

Important Notes:

- A qualified installer or service technician must perform equipment installation or service. Contact Aqua-Hot for Factory Authorized Service Centers or Certified technicians located near you at www.airxcel.com/rv/eu/heating-systems, or call us at +39 0424 1953311.
- Warranty work must be performed by an Aqua-Hot Factory Authorized Service Center.
- Your on-product identity label contains the specifications of your unit. Factory settings may be adjusted by the vehicle manufacturer, confirm final setting with your dealer.



- Follow this guide exactly. Failure to do so may result in a fire or explosion resulting in property damage and/or personal injury.

Contents

Caution Notes.....2

Safety Features3

Component Call-outs5

System Features6

Operational Overview.....7

Operating the LCD.....8

Aqua-Hot Layout.....14

Maintenance Schedule.....15

Winterizing the Aqua-Hot.....16

General Troubleshooting.....17

Owner’s Service Log18

Warranty20

Caution Notes

As you read this information, take particular note of the NOTICE, CAUTION, WARNING, and DANGER symbols when they appear. This information is important for safe and efficient use of the Aqua-Hot system.

NOTICE signals a situation where potential damage to the Aqua-Hot could occur.



CAUTION signals a situation where potential harm or risk of minor or moderate injury could occur if you do not follow instructions.



WARNING signals a hazardous situation where potential harm, risk of serious injury, or death could result if instructions are not followed.



DANGER signals a situation where immediate risk of serious injury or death will result if instructions are not followed.





NOTE: This manual will also use notes sections similar to this one to draw attention to features and practices which must be observed.

 **WARNING**

WHAT TO DO IF YOU SMELL GAS

- Evacuate all persons from the vehicle.
- Shut off the gas supply at the gas container or source.
- Do not touch any electrical switch or use any phone or radio in the vehicle.
- Do not start the vehicle’s engine or electric generator.
- Contact the nearest gas supplier or qualified service technician for repairs.
- If you cannot reach a gas supplier or qualified service technician, contact the nearest fire department.
- Do NOT run the first operation until it has been confirmed there are no gas leaks.
- Do not turn on the gas supply until the gas leak(s) have been repaired.

 **DANGER**



Water temperature over 52°C can cause severe burns instantly, or death from scalds. Children, disabled, and elderly are at highest risk of being scalded. See instruction manual before setting temperature at water heater. Feel water before bathing or showering! Temperature limiting valves are available.



Read and understand all instructions **before** installing the Aqua-Hot system. Aqua-Hot Heating Systems is not liable for damage resulting from failing to follow instructions contained in this, and any other Aqua-Hot documentation relevant to this unit.

- Read this manual **before** installing or using the Aqua-Hot System to reduce the risk of injury to persons or damage to the equipment.
- The product identity label contains specifications of the unit, to what standards it has been tested, and important safety notices.
- Disconnect electric wiring to the Aqua-Hot System before welding or plasma cutting the RV to avoid damage to the electrical components.
- The Gen 1 tank must have a cold water inlet pressure regulator set to 2.8bar or below to avoid damage to the tank.



- Use caution when working on or near any diesel fuel system.
- DO NOT connect the 12-volt DC power to the Aqua-Hot if the vehicle requires welding.
- Use special caution when children are present. Children must not be allowed to play with the heater or perform cleaning and maintenance.
- All vehicle installations must comply with the requirements of National Legislation and Regulations standards.
- At maximum operating temperature, the hot air outlet will be very hot that may result in serious burns or injury. Be aware of hot surfaces..



System Overview

The Aqua-Hot Gen 1 Heater is a forced air heating system that can provide heat and supplementary hot water using a built-in electric heating element and a diesel burner.

There are three options for heating:

- **Diesel Mode:** the heater automatically adjusts power according to temperatures.
- **Electric Mode:** manually select either the 900W or 1800W heating mode according to the power supply capacity of the shore power.
- **Hybrid Mode:** when the power demand is low, the electric heating is prioritized. For higher heating needs, the burner will automatically activate.

Important Notes:

- A qualified installer or service technician must perform equipment installation or service.
- Installation, repairs, and warranty work may only be carried out by a qualified technician. The heating system must be installed in accordance with local codes, or the National Legislation and Regulations.
- Aqua-Hot will not be liable for problems or damage caused by the system being installed by untrained technicians.
- This heating system has been certified for installation only in recreational vehicles as a Class I Appliance, not certified for use in boats.
- The Aqua-Hot heating system operates independently of the vehicle engine and is connected directly to the electrical system of the vehicle or towable.
- Please read this manual and follow instructions to avoid injuries during installation and/or operation.

NOTE: Contact your Authorized Service Center or Aqua-Hot Heating Systems if you have any questions **before** starting installation. Information can be found online at <https://airxcel.eu>.

All vehicle installations must comply with national legislation and regulations.

 This unit is CE certified. Any modifications made to this unit not outlined in official literature or expressly authorized by Aqua-Hot will void this certification.

Safe Operation

The Aqua-Hot Heating system consists of an electric heating element and a diesel burner. The heater with supplementary indirect water heating is for use in RVs only to heat the space and domestic water.

The room heater works by pulling air into the heater by a fan, heated up, and dispensed into the RV's interior by ductwork.

The water heating is installed between the fresh water supply line and the hot water system. The hot water system incorporates a mixing valve to produce non-scalding hot water.

Locate the LCD screen (shown below) inside the RV (contact the vehicle manufacturer if unable to find), press and hold the turn knob to wake, use the rotary button to select the desired energy mode. Click the rotary button to confirm. It will take approximately 20 minutes for the heater to get to operating temperature. After the tank is to temperature, you can turn on the heat on your RV thermostat/LCD or run hot water.



Figure 1

General Care

- To maintain the Aqua-Hot at its full potential, it is highly recommended to have the burner tuned up after 1000 hours of burner run time:

NOTE: If white or black smoke is seen, this is a good indicator that service is necessary.

- If the system has not been used for long periods of time, thoroughly flush all hot/cold water lines before use.
- It is recommended to run the burner once a month (~20 minutes) to ensure optimum heater condition.
- The water tanks must be cleaned regularly, minimum of twice a year. When the RV is driving or in storage, the temperature range should not exceed the range of 40-85 °C to prevent damage to the electronic components.
- It is necessary to take precautions during any user maintenance.

Intended Use

This manual explains the operation and care of the Aqua-Hot heating system.

These instructions are approved for the Aqua-Hot Gen 1 diesel model for recreational vehicles only. Not for use in boats.

- Service, repairs, and warranty work may only be carried out by a qualified technician. The heating system must be installed in accordance with local codes, or the National Legislation and Regulations.
- The vehicle owner is responsible for correct operation of the appliance.
- The Aqua-Hot heater must comply with the codes and regulations of the country it is being used in. National Legislation and Regulations, and local codes must be followed.
- Make sure to properly winterize the Aqua-Hot's domestic water system when not in use and/or any time the heater is stored where freezing temperatures may be experienced. The Aqua-Hot warranty will not cover claims for freeze damage. Please refer to page 16 for proper winterization of the Aqua-Hot.

Aqua-Hot Gen 1 Heater

1. Heater
2. Combustion Air Inlet
3. Exhaust Outlet
4. Controller Cover
5. Plastic Frame Feet
6. Aluminum Frame Feet
7. Circulated Air Intake
8. Cold Water Connection (Inlet)
9. Diesel Fuel Connection
10. Hot Water Connection (Outlet)
11. Fan for Combustion Air
12. Water Tank
13. Warm Air Outlets (Upper)
14. Warm Air Outlets (Lower)
15. Recessed Grips
16. Electronic Control Unit
17. LCD Control Screen

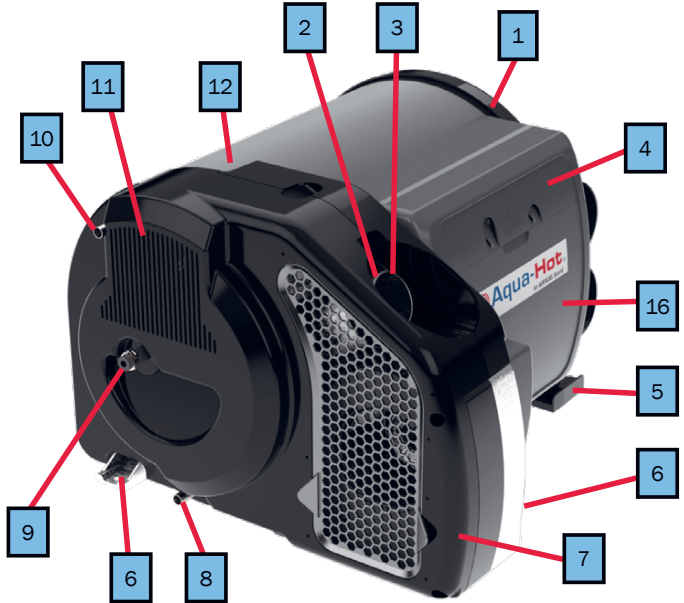

Figure 2

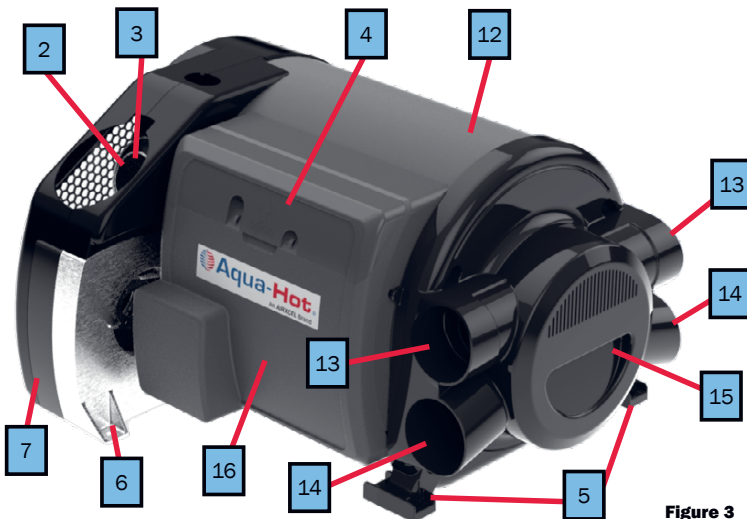

Figure 3



Figure 4

System Features

The Aqua-Hot Gen 1 Heater is a forced air heating system that can provide heat and supplementary hot water using a built-in electric heating element and a diesel burner.

There are three options for heating:

- **Diesel Mode:** the heater automatically adjusts power according to temperatures.
- **Electric Mode:** manually select either the 900W or 1800W heating mode according to the power supply capacity of the shore power.
- **Hybrid Mode:** when the power demand is low, the electric heating is prioritized. For higher heating needs, the burner will automatically activate.
- When plugged into shore power, or powered by a generator, the electric element lets you use the power you are already paying for to provide heat in mild conditions and meet your light duty hot water needs.
- The diesel burner can be utilized with the electric element to heat and supplementary produce hot water.





Aqua-Hot[®]
An **AIRXCEL** Brand

For full details and installation requirements, please see installation and owner's manuals.

Minimum Service Clearances:
 Front: 10 cm
 Back: 2.5 cm
 Sides: 1.25 cm
 Top: 5 cm
 Bottom: No clearance Necessary
 This appliance must be installed in accordance with local codes, or in absence of local codes, follow EN-1949.







Max Tank Pressure	4.5 bar (450 kPa)
Tank Capacity	10L
Power (DC)	12VDC, 10A, 120W Max
Power (AC)	240VAC, 7.8A, 1800W Max
Burner	Diesel, 4kW

Model: 1000516
Serial Number: XXXXXXXX

NOTE: This product label is attached to the side of the Aqua-Hot, and provides a ready reference to specifications, test standards, and important safety notices.

All vehicle installations must comply with national legislation and regulations.

 This unit is CE certified. Any modifications made to this unit not outlined in official literature or expressly authorized by Aqua-Hot will void this certification.

Operational Overview

Energy Setting

The Aqua-Hot Gen 1 heater has three available energy sources: Fuel, Electric and Hybrid.

Fuel

When "Fuel" is selected in the energy setting menu the heater will use on-board fuel to generate heat.

Electric

In the energy setting menu, EL1 or EL2 can be selected. EL1 activates 900W of electric heating elements. EL2 activates 1800W of electric heating elements. EL2 can only be used when 10A 220V AC service is available.

Mix Mode (Hybrid)

Hybrid mode is activated by selecting MIX1 or MIX 2. In each mode the diesel burner is activated along with supplemental heat from the electric elements. In MIX1 900W of electric heating is supplied. In MIX2, 1800W of electric heating is supplied. MIX2 should only be used when 10A 220V AC service is available.

NOTE: In Mix mode, the electric element will take priority over the burner unless the heating demand cannot be met by the electric element, in which case the burner will activate.

Interior Heat

When interior heating is activated the burner or electric elements heat a heat exchanger. Air is forced across the heat exchanger and warmed. Ducting routes the warm air throughout the vehicle. The external temperature sensor reads the temperature of the vehicle and activates the flow of warm air through the vehicle.

Hot water

When hot water mode is activated the burner or electric elements heat a heat exchanger. The heat exchanger transfers heat to the water tank and warms the water. When a hot water faucet is opened, hot water flows from the tank through the faucet. Cool domestic water is pumped back into the tank, which remains full, and is heated.

Combination

When both hot water and interior heat modes are activated, the heat from the burner or electric elements is distributed to both hot air and hot water. If boost water mode is selected, interior heat will be temporarily paused to prioritize the creation of hot water.

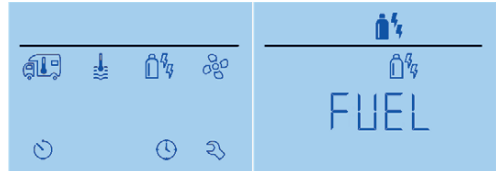

Figure 5

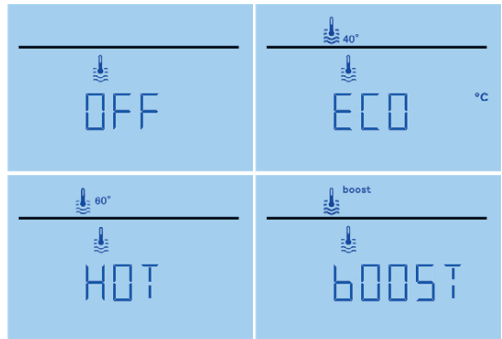
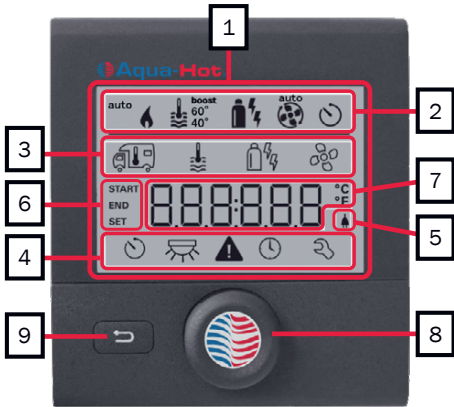

Figure 6

Working Mode	Energy Mode
OFF	Water heating is off - icon will not show
ECO	Water Temperature target of 40 °C
HOT	Water Temperature target of 60 °C
BOOST	Prioritizes water heating for 40 minutes or until the water temperature reaches 60 °C

Operating the LCD



1 Display Area	6 Timing Display
2 Status Display	7 Parameter Setup Display
3 Menu Bar (top)	8 Rotary Button/Knob
4 Menu Bar (bottom)	9 Return Button
5 220V Electrical Display	

Display and Control Section:

- The information is displayed on the screen with a back-light
- In the menu bar (#3, 4), the function of the LCD can be selected. The operating parameters are shown on the status bar (2) and display bar (5, 6).
- After the 220V is supplied to the system, the 220V power supply indication column (5) displays the power supply sign
- During heater operation, set the parameter bar (7) to display start/end times, and room temperature.
- Press the return button (9) to return to previous interface.

Rotary button (8)

- Select, modify, and save icons for menu bars 3 & 4 by rotating the knob.
- Tap the button to confirm saving and return to main menu.
- Press and hold the button (+3seconds) to turn on/off LCD.

Power ON:

Hold the rotary button for 3seconds to turn on LCD. After a few seconds, the time is displayed as 00:00.

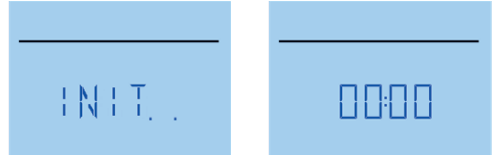

Click the rotary button to display the initial options in the display.

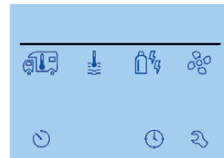

Clock setting (current time setting)

- Click the rotary button to display the icon in the menu bar (3).

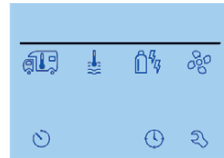

- Use the rotary button to select "Set Clock" icon in the menu bar (4).
- Click the rotary button to enter the clock settings.



- Use the rotary button to set the time. "A-" is displayed in the morning and "P-" is displayed in the afternoon
- Click the rotary button again to determine the time, then the minute display flashes.
- Set the minute with the rotary button.
- Click the rotary button to confirm the value and exit the clock setting.
- Rotate button to start
- Press the rotary button for 3 seconds, the LCD will start.

Shutdown

Press the rotary button for more than 3s at the initial interface to shut down. When the LCD switch is turned off, the heating process and any connected equipment are also automatically turned off. The parameters before shutdown are retained.



Downtime Process (Cool-Down Cycle)

Since the heater has a higher residual heat after heating and a post-cleaning need, the fan typically runs for a few minutes for cooling.

Heating Function Settings

The heating function setting should first set the fuel, and then select water heating or room heating or simultaneous heating, and finally set the fan speed. The default heating function settings is the fuel setting and the fan speed setting ECO.

Energy Setting

- Rotate the button to select the fuel icon in the menu bar (3).
- Click on the selected icon.

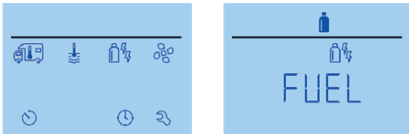

- Use the rotary button to select the desired fuel mode.
- Click the rotary button to confirm.

If the fuel type is not selected, once the heater starts to operate (room temperature, hot water icon is activated), the status bar shows the type of fuel selected during the previous heating process or the fuel type set at the factory.

Working Mode	Energy Mode
FUEL	Diesel
MIX 1	Electric 900W + FUEL
MIX 2	Electric 1800W + FUEL
EL 1	Electric 900W
EL 2	Electric 1800W

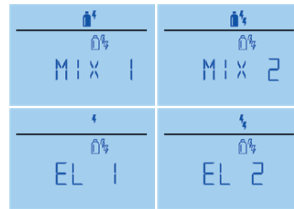

Adjustment of Interior Temperature

- Click the rotary button to display the icon in the menu bar (3). Select the room temperature heating system with the rotary button according to the connected device.
- Confirm the selection by clicking the rotary button on the selected room temperature icon.
- Use the rotary button to select the desired temperature.
- Click the rotary button to confirm its value.

Temperature Display	°C / °F
Temperature Range	5-30°C / 41-86°F
Increments	1° C/F

This flame icon will be on when room temperature heating starts, this icon will flash until the predetermined room temperature is reached.



Adjustment of Water Heating

- Click the rotary button to display the icon in the menu bar.
- Use the rotary button to select the desired water temperature setting level.
- Click the rotary button to confirm

Working Mode	Energy Mode
OFF	Water heating is off - icon will not show
ECO	Water Temperature target of 40°C
HOT	Water Temperature target of 60°C
BOOST	Heats the water for 40 minutes or until the water temperature reaches 60°C



Operating the LCD

. This icon will flash until the predetermined water temperature is reached.

In the "heating and hot water mode", the water temperature of 40°C can only be stored for a limited time (room heating priority).

Adjustment of Fan Speed (when air heating is enabled)

- Click the rotary button to display the icon in the menu bar.
- Use the rotary button to select the desired fan speed setting level.
- Click the rotary button to confirm.

Working Mode	Energy Mode
OFF	Fan is off - icon will not show
VENT	Circulation ventilation. Can choose 10 levels of fan speed.
ECO	Low fan speed
LOW	Mid-speed
HIGH	High fan speed
BOOST	Fastest fan speed



Adjustment of Vent Fan Speed

NOTE: Vent Fan is for air circulation without heating.

- Only available when air heating is not enabled
- Select OFF or VENT

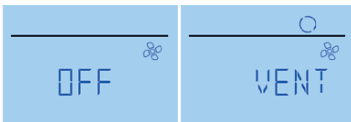

- If VENT is selected, set the fan speed between 1-10.

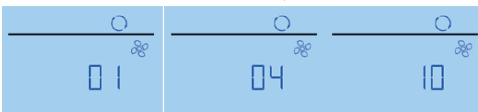

Heating Start

After the setting is finished, press the return key or wait for 10s to enter the clock interface, and the heating starts. The clock and set temperature are displayed alternately.

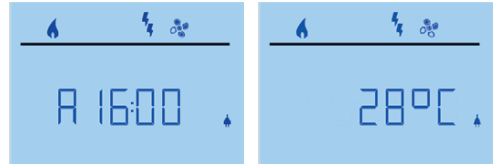

Heating End

Press and hold the rotary button for 3 seconds to shut down.

Timing Heating Settings

- Click the rotary button to display the icon in the menu bar (3).
- Click the rotary button to enter the timing settings.

 **WARNING**

DANGER OF TOXIC EXHAUST FUMES

Even if the vehicle is stopped, unmanned, the activated time switch will turn on the heater. Exhaust gases from heaters may be toxic in confined spaces such as garages, workshops, and repair shops.

If the vehicle is parked in a closed room:

- Turn off the fuel supply to the heater.
- Turn off the timer switch of the LCD switch.
- Turn off the heater on the LCD switch. Press and hold the rotary button for 3 seconds to turn off.

Enter the Start-up Time

- Use the rotary button to set the start time.
- Click the rotary button to confirm and proceed to the next setting.

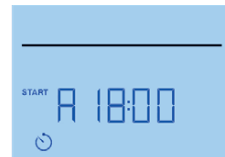

Enter the End Time

- Use the rotary button to set the end time.
- Click the rotary button to confirm and proceed to the next setting.

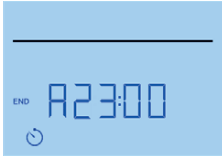

Select Fan Speed Level

- Use the rotary button to set the desired fan speed
- Click the rotary button to confirm and proceed to the next setting.



Set Room Temperature

- Use the rotary button to set the desired temperature
- Click the rotary button to confirm and proceed to the next setting.

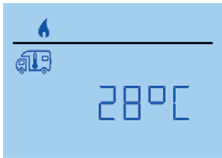

Enable Timer

- Use the rotary button to select Enable Timing (ON). If OFF is selected, the timer is canceled, but the settings are saved.
- Click the rotary button to confirm and proceed to the next setting.



Set Water Temperature

- Use the rotary button to set the desired temperature
- Click the rotary button to confirm and proceed to the next setting.

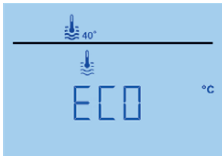

The time switch is only enabled once until it is disabled (turned off) or powered down. If the timer switch is programmed and enabled, the time switch icon is displayed in the status line (2). The timing icon flashes if the time switch is enabled and activated.

Cancel Timer

- With the timing set, use the rotary button to select the timing setting. Click the rotary button to enter the settings.
- Use the rotary button to select the cancel timing (OFF). If you select ON, continue to use timing. Click the rotary button to confirm that the cancellation timing is valid. But the previous settings are still saved

Fuel Mode Selection

- Use the rotary button to set the desired fuel mode
- Click the rotary button to confirm and proceed to the next setting.

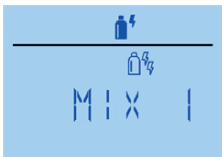

Parameter Settings

The content after the parameter setting is maintained after the power is turned off. Use the rotary button to select the "Settings" icon in the menu bar (4). Click the button to enter the settings.

Operating the LCD

Voltage Inquiry

- Click the rotation button to display the voltage: 12.0V.

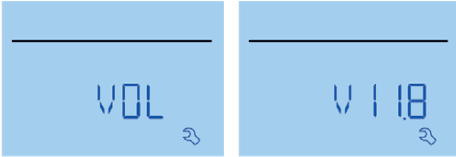

Air Pressure and Temperature Inquiry

- Click the rotation button to select the at ATMOS icon.
- Click the rotary button to enter the selection



- Use the rotary button to switch between atmospheric pressure and ambient temperature.

Atmospheric pressure: 99kPa **Ambient temperature:** 26°C

Offset Setting

The external temperature sensor of the heater can be adjusted separately depending on the installation of the sensor. The offset setting can be in the range of -5°C to 5°C. The deviation is 1°C.

- Click the rotation button to select the OFFSET icon.
- Click the rotary button to enter the selection

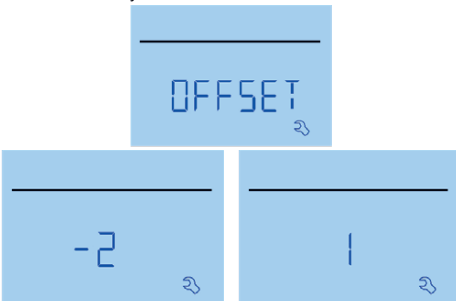

Switching Temperature Units

Use the knob to switch between Celsius and Fahrenheit, then click to confirm

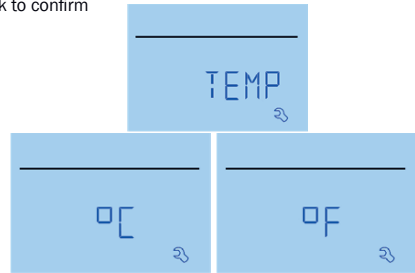

LCD Backlight Adjustment

The LCD backlight has 10 levels of incremental adjustment.

Use the rotary button to select the BRIGHT icon and click the rotate button to enter the settings.

The brightness of the LCD changes as the rotary button rotates. After confirming by clicking the rotary button, return to the previous operation. The backlight brightness is set to 6 by default.

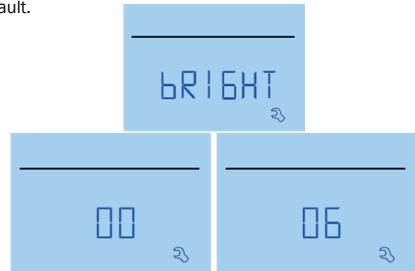

Time Settings

Use the rotary button to select the time format setting icon and click the rotary button to enter the settings. Use the rotary button to select the 12h or 24h icon and click the rotary button to confirm. The default setting is 24h.

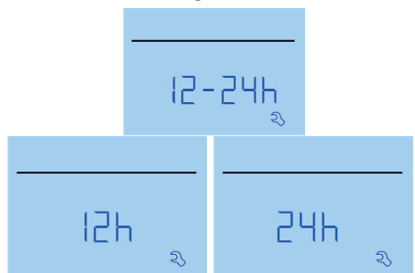

Fast Pump Settings

NOTE: The Fast Pump/GoOil feature must only be used for system priming with the fuel line disconnected from the heater. Do not attempt to use this feature with the fuel line connected to the heater.

Select pump oil icon GoOil with rotary button.

- Click on the rotary button to enter the fast pump oil. The default fast pump time is 90 seconds. The remaining time can be adjusted with a knob.
- Press the return key or stop the fast pump if the pump oil time exceeds the set value.



Software Version Number

- Use the rotary button to select the INDEX icon and click the rotary button to enter the query item.
- Use the rotary button to view the information of the LCD switch or the information of the main controller.
- Click the rotary button or want to go back to return to the previous operation.

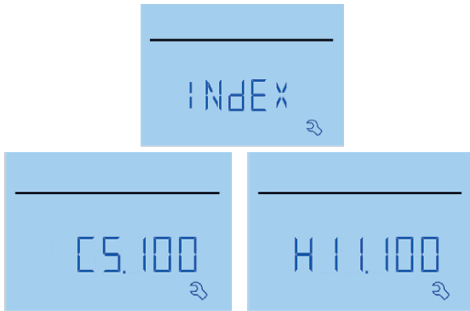

C5.100 - LCD Version **H11.10** - Master Controller Version

Factory Settings

- The reset function resets the LCD switch to factory settings. All previous settings will be deleted. All devices used before RESET is installed and powered.
- Use the rotary button to select the RESET icon and click the rotary button to display the factory setting PR SET.
- After confirming, the initialization "INIT...." is displayed.

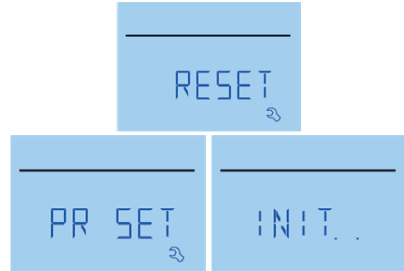

Fault Display

- Use the rotary button to select the icon and click the rotary button to display the current warning code (for troubleshooting, please refer to the relevant heater instruction manual).
- There are faults in the fault that are automatically recovered and manually recovered after repair.
- An automatic recovery fault is a warning fault in which an operating parameter has exceeded a defined normal working range and reached an undefined state. In this case, the device will continue to run and the warning symbol (▲) will be displayed in the menu bar (4) without warning code. After the fault is repaired, the warning symbol disappears automatically (it can also be manually restored), and the device continues to work according to the original settings. For example: warning fault code W 120 H.
- A manually recovered fault means that the fault code is displayed in the parameter setting 8 field (7) when the fault occurs. The cause of the fault can be determined and remedied by the help of the troubleshooting guide. The fault code disappears after a few seconds, and the warning disappears, and the warning symbol is displayed in the menu bar (4).
- Select Reheat after the fault is identified and resolved, first remove the fault code. Press the rotary button to display the fault code, then press the rotary button, the displayed fault code disappears and return to the initial time interface. Re-enter the heating parameters to initiate heating. If the fault is removed, the heating will be normal or the fault will occur again. The LCD switch will jump to the "Fault" menu again, the warning symbol will be displayed again, and the affected device will still be in the warning state. Since the fault has not been eliminated, if you want to return to the set level, press the back button (9). For example: fault code E 31 H. Shutdown and power off can also eliminate faults.

The fault code table and troubleshooting methods can be found in the tenth fault code table at the end of the manual.

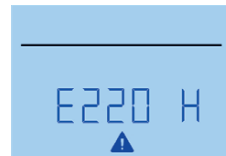

Aqua-Hot Layout

NOTE: The illustration below is just a sample for the layout of the Aqua-Hot heating system. Actual placement may vary on the individual design of the RV. For questions or assistance, contact us at +39 0424 1953311.

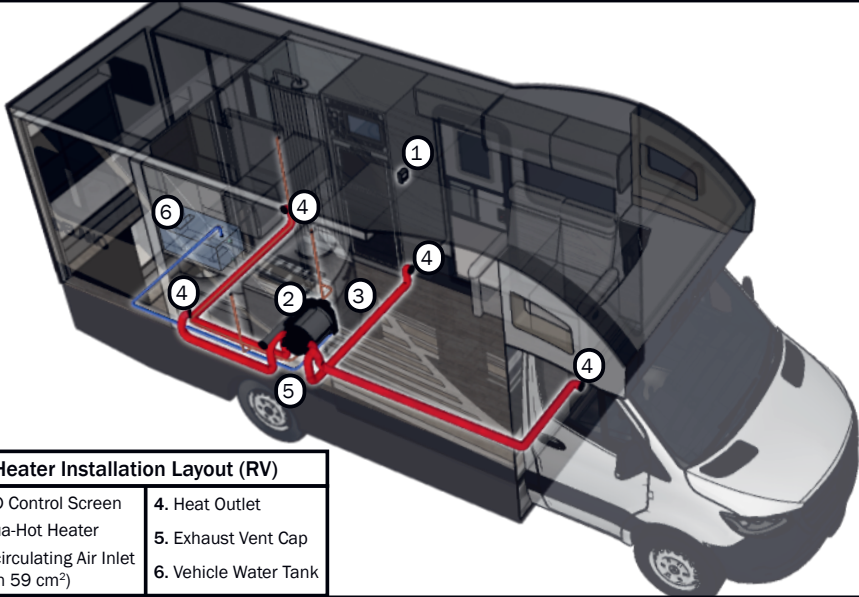

Heater Installation Layout (RV)

- | | |
|---|-----------------------|
| 1. LCD Control Screen | 4. Heat Outlet |
| 2. Aqua-Hot Heater | 5. Exhaust Vent Cap |
| 3. Recirculating Air Inlet
(min 59 cm ²) | 6. Vehicle Water Tank |

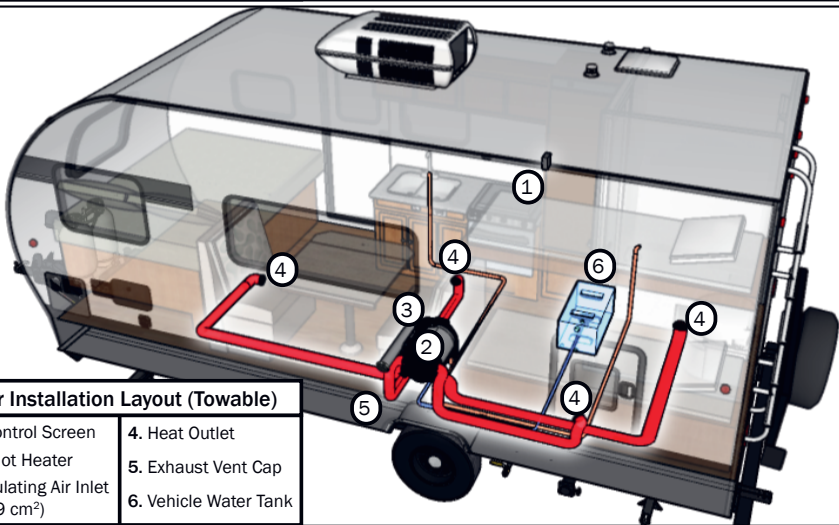

Heater Installation Layout (Towable)

- | | |
|---|-----------------------|
| 1. LCD Control Screen | 4. Heat Outlet |
| 2. Aqua-Hot Heater | 5. Exhaust Vent Cap |
| 3. Recirculating Air Inlet
(min 59 cm ²) | 6. Vehicle Water Tank |

Figure 7

Maintenance & Storage

Monthly Maintenance

- Check the exhaust and air intake systems
Ensure there is no damage or leaks, inspect the exhaust bulkhead gasket for a proper seal. Replace any damaged components.
- Check the fuel system
Check for abrasion along the fuel line. Inspect the rubber couplers for cracking. Ensure there are no leaks. Replace any damaged components.
- Check the vent air path
Check for blockages in cold air return path. Check the ducting for any damage.

NOTE: It is recommended to run the burner once a month (~20 minutes) to ensure optimum heater condition.

1000-Hour Maintenance

To maintain the Aqua-Hot at its full potential, it is highly recommended to have the burner tuned up after 1000 hours of burner run time:

NOTE: If white or black smoke is seen, this is a good indicator that service is necessary.

- Cleaning the burner: replace fuel filter, clean combustion chamber, clean glow plug, clean flame sensor.
- Inspecting the exhaust and air intake lines for damage and ensuring they are clear
- Checking the fuel lines for any leaks
- Checking the hoses and wiring to make sure there are no damage or cracks.

Storage

If the system has not been used for long periods of time, thoroughly flush all hot/cold water lines before use. It is recommended to run the heater at least once a month for 10-20 minutes to ensure optimum heater condition.

The water tanks must be cleaned regularly, minimum of twice a year. When the RV is driving or in storage, the temperature range should not exceed the range of 40-85 °C to prevent damage to the electronic components.



THE AQUA-HOT'S EXHAUST IS HOT!

- Do NOT operate the burner inside an enclosed building.
- The heater must be switched OFF when refueling.
- The heater is not to be operated while the vehicle is being refueled, if the towing vehicle is being refueled, or if the vehicle is in an enclosed space.
- The heater is not to be used while any appliances are being refueled or serviced.
- Aqua-Hot will not be liable for problems and/or damage caused by the system installed by untrained technicians.

If the vehicle is parked in a closed room:

- Turn off the fuel supply to the heater.
- Turn off the timer switch of the LCD switch.
- Turn off the heater on the LCD switch. Press and hold the rotary button for 3 seconds to turn off (see below).

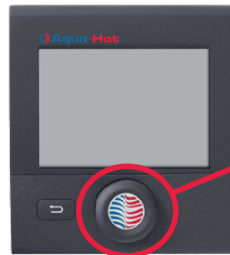

Figure 8

Rotary Button / Turn Knob
Press and hold for 3 seconds to turn off



Winterization

To avoid freeze damage to the system, the heater must be drained through the drain valve completely. If water is left in the system in below freezing temperatures, it can cause severe damage to the system that is not covered under warranty.

NOTE: The Aqua-Hot can continue to be used for interior heat once the domestic hot water system has been winterized.

- Turn off power supply and open hot water faucets in the RV.
- Place a container under the drain valve to catch the fluid.
- Open the drain valve and allow the fluid to drain out completely.

It is recommended to winterize if the RV will be stored for a long time or the system will not be used, and it is below freezing.

WARNING

Not winterizing the Aqua-Hot when freezing temperatures are present will result in serious damage to the Aqua-Hot domestic water heating system. The warranty does not cover freeze damage.

Disinfecting the Domestic Water System

NOTICE

The Aqua-Hot Heating components are not compatible to prolonged exposure to sodium hypochlorite (bleach or liquid bleach). Using products containing bleach, including water refreshers, may cause corrosion of the domestic water lines, resulting in a catastrophic failure of the Aqua-Hot system by creating leaks that cannot be repaired. This damage is not covered by the Aqua-Hot warranty.

If disinfecting the hot water system, be sure to follow any current national regulations or any other applicable local standards for Water Systems.

DANGER

Water temperature over 52 °C can cause severe burns instantly, or death from scalds. Water temperature coming from the heater will be at 71 °C . Feel water before bathing or showering! Temperature limiting valves are available.

Domestic Hot Water Installation Layout

- | | |
|---------------------------|---------------------------|
| 1. Pressure Relief Valve | 7. Domestic Water Lines |
| 2. Cold Water Inlet | 8. Pressure Regulator |
| 3. Hot Water Outlet | 9. City Water Hook-Up |
| 4. Drain Valve | 10. Water Tank Connection |
| 5. Tempering Valve | 11. Water Pump |
| 6. Non-Return Check Valve | 12. Fresh Water Tank |

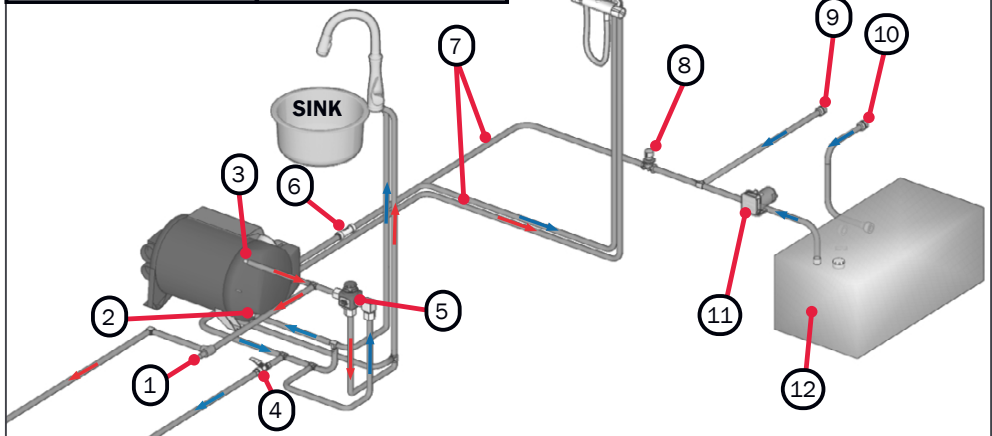

Figure 9

Troubleshooting

- Ensure that the system is supplied with electrical power and there are no blown fuses.
- Ensure that there is at least ¾ tank of fuel in the vehicle fuel supply and the fuel filter is not clogged.
- Make sure all the electrical and plumbing connections are connected and secure.
- Ensure there are no faults on the LCD. If there are, determine the fault and remedy. Refer to the table below for the fault code.

Fault Codes			Error Code	Fault Name	Remedy
Error Code	Fault Name	Remedy			
10	Over-voltage	Check vehicle power supply	43	Water overheat	<ul style="list-style-type: none"> • Check water tank levels • Check sensor wiring/connections • Check air outlet for blockages
11	Low Voltage	Check vehicle power supply	44	Warm air overheat switch protection	<ul style="list-style-type: none"> • Check air outlet for blockages • Check warm air overheat switch
21	Warm air outlet temperature sensor disconnect	Check temperature sensor connections	45	Overheat fault	<ul style="list-style-type: none"> • Check air outlet for blockages • Check water temperature sensor • Check warm air sensor
22	Warm air outlet temperature sensor short circuit	Check temperature sensor wiring	51	Communication fault	Check interconnecting cable
23	Water temperature sensor disconnect	Check temperature sensor connections	61	Fuel Pump Break	<ul style="list-style-type: none"> • Check fuel pump lead for damage • Check fuel pump wire connections • Replace fuel pump • Replace controller
24	Water Temperature sensor short circuit	Check temperature sensor wiring	62	Fuel pump short circuit	<ul style="list-style-type: none"> • Check fuel pump lead for damage • Check fuel pump wire connections • Replace fuel pump • Replace controller
25	External temperature sensor disconnect	Check temperature sensor connections	63	Electric element circuit broken	<ul style="list-style-type: none"> • Check power supply voltage • Check resistance at room temp (0.2/12V) • Clean any carbon build-up • Replace controller
26	External Temperature sensor short circuit	Check temperature sensor wiring	65	No power to electric element	Replace controller
27	Combustion support temperature sensor disconnect	Check temperature sensor connections	81	Combustion fan disconnect	Check combustion air blower
28	Combustion support temperature sensor disconnect	Check temperature sensor wiring	82	Combustion blower boot failure	<ul style="list-style-type: none"> • Check blower motor lead wire • Check combustion air blower
31	Combustion Failure	<ul style="list-style-type: none"> • Check gas supply system • Check combustion inlet and outlet are blocked • Check ignition coil, electrode • Flame sensor 	83	Combustion blower speed too low	Check combustion air blower motor
32	Combustion failure	<ul style="list-style-type: none"> • Check gas supply system • Check combustion inlet and outlet are blocked • Check Flame sensor 	84	Warm air blower motor disconnect	Check warm air blower motor
33	Flame sensor fault	<ul style="list-style-type: none"> • Check flame sensor lead wire • Check flame sensor 	85	Warm air blower motor boot failure	<ul style="list-style-type: none"> • Check blower motor lead wire • Check warm air blower motor
41	Warm air outlet overheats	Check air outlet for blockages	86	Warm air blower speed too low	Check warm air blower motor
42	Warm air overheat switch protection	<ul style="list-style-type: none"> • Check whether air outlet is blocked • Check warm air overheat switch 	110	Window alarm	Check window switch cable
			120	Low Voltage Fault	Check power supply and connections
			220	220V Disconnect	Check AC 220V/110V power supply

Heater Lock-out Reset Procedure

To reset the heater from a lock-out, simply turn off the heater and disconnect power supply to the heater, wait for 20 seconds, then reconnect power supply and restart the system.

Service Log

DATE	SERVICE PERFORMED	SERVICE CENTER

DATE	SERVICE PERFORMED	SERVICE CENTER

Warranty



2-YEAR LIMITED WARRANTY AQUA-HOT® HYDRONIC HEATING SYSTEM

Aqua-Hot Heating Systems Inc. warrants the Aqua-Hot Heater to be free from defects in material and workmanship under normal use and service for a period of two years on both parts and labor commencing upon the original date of registration of the vehicle. Replacement parts are warranted for the remainder of the Heater's standard warranty coverage or for six months, whichever is greater. The intent of this warranty is to protect the heater's end-user from such defects, which would occur in the manufacturing of the product. Thus, problems due to improper specifications, improper installations, improper use, the use of accessory parts or parts not authorized by Aqua-Hot Heating Systems Inc., repair by unauthorized persons, and damage or abuse of the heater are specially excluded from warranty coverage.

For additional information, or to obtain a warranty repair authorization, please contact the Aqua-Hot Heating Systems Warranty Administrator at +39 0424 1953311 (08:00 to 16:00 CET Monday through Friday) or visit www.airxcel.com/rv/eu/heating-systems.

My Comfort Zones are On-Board

Vehicle:

Purchased From:

Dealer Information:

Name:

Location:

Phone Number:

Heating System:

Serial Number:

Operational Guide

Gen 1 SERIES

 **Aqua-Hot**[®]
An AIRXCEL Brand

Gen 1 DIESEL
1000516



AIRXCEL EUROPE - CAN S.R.L.
Via G. Apollonio 11
36061 Bassano Del Grappa - (VI)
Italy

Visit us online at <https://airxcel.eu>
Tel +39 0424 1953311
Fax +39 0424 1953399

©2023 Aqua-Hot Heating Systems, LLC.